

REVISION INFORMATION			
Rev.	Rev. Date	Modified By	Brief Description

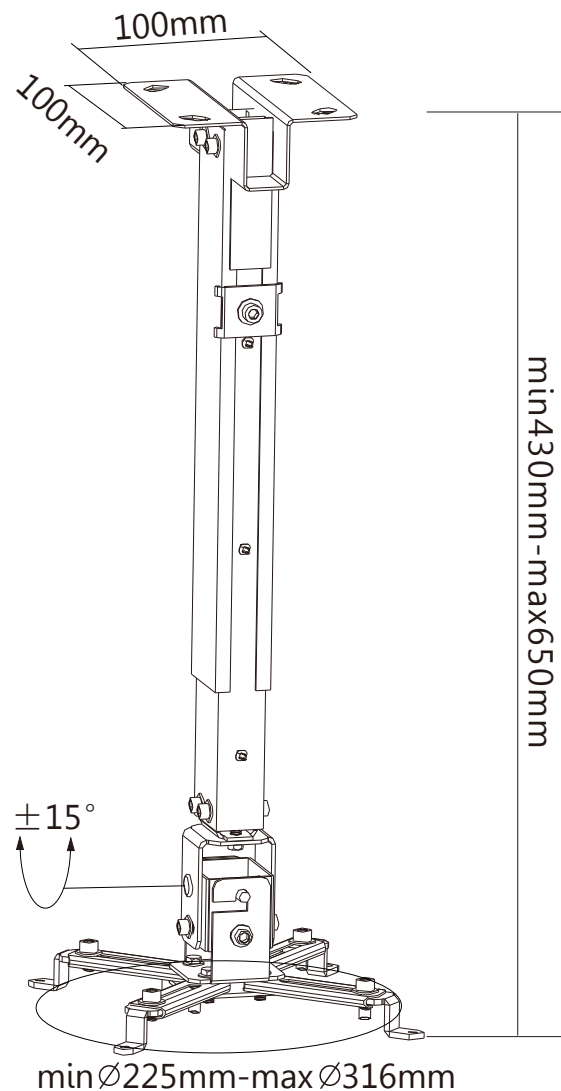

	M5x10 (x6)
	M6x10 (x4)
	M5x8 (x4)
	M4x8 (x4)
	M3x8 (x4)
	D3 (x4)
	D4 (x4)
	D5 (x10)
	D5 (x2)
	D6 (x4)
	4mm (x1)
	5mm (x1)
	94mm (x2)
	ST6.3x55 (x4)
	x4
	x4

* All of materials satisfy the CA65, ROHS...

GENERAL TOLERANCE		APPROVED BY & DATE :	DESCRIPTION :			
0-6	±0.05	CHECKED BY & DATE :	Ceiling Bracket for Projector (Max 44Lbs) - BLACK			
6-18	±0.07					
18-50	±0.10	DESIGNED BY & DATE :	ITEM NO. : 5466			
50-120	±0.15		DATE : 2017/01/10	REV : A01	UNIT : MM	SHEET : 1 OF 2

NO.	PART NAME	SPECIFICATION DESCRIPTION	QTY	UNIT
③				
②				
①	5466	Ceiling Bracket for Projector (Max 44Lbs) - BLACK		