

11918

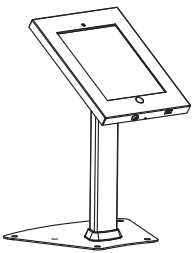







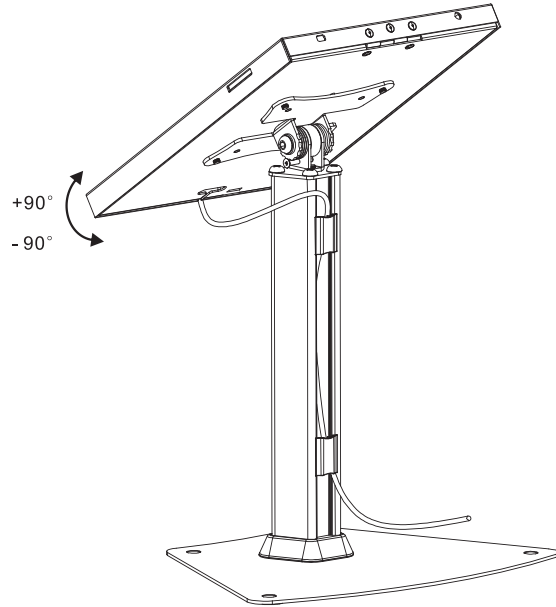









## Safe and Secure Tablet Desktop Display Stand for iPad® 2, iPad® 3, iPad® 4, iPad Air™ - Black

### Installation Instruction

8



ITEM	DESCRIPTION/PART NO.	QUANTITY	ITEM	DESCRIPTION/PART NO.	QUANTITY
A	 Pole	1	I	 Silicone Pad (D)	1
B	 Anti-Theft Box	1	J	 Silicone Pad (E)	1
C	 Base	1	K	 Silicone Pad (F)	1
D	 Plastic Pad	1	L	 M6 x 16	4
E	 Key	2	M	 ST5.5x38	4
F	 Silicone Pad (A)	2	N	 Concrete Anchor	4
G	 Silicone Pad (B)	2	O	 Allen Key	1
H	 Silicone Pad (C)	1	P	 M5x8	4

### Technical Support

Monoprice is pleased to provide free, live, online technical support to assist you with any questions you may have about installation, setup, troubleshooting or product recommendations. If you ever need assistance with your new product, please come online to talk to one of our friendly and knowledgeable Tech Support Associates. Technical support is available through the online chat button on our website [www.monoprice.com](http://www.monoprice.com) during regular business hours, 7 days a week. You can also get assistance through email by sending a message to [tech@monoprice.com](mailto:tech@monoprice.com).

1

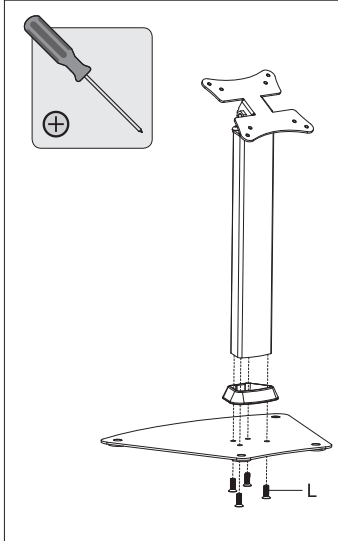

2

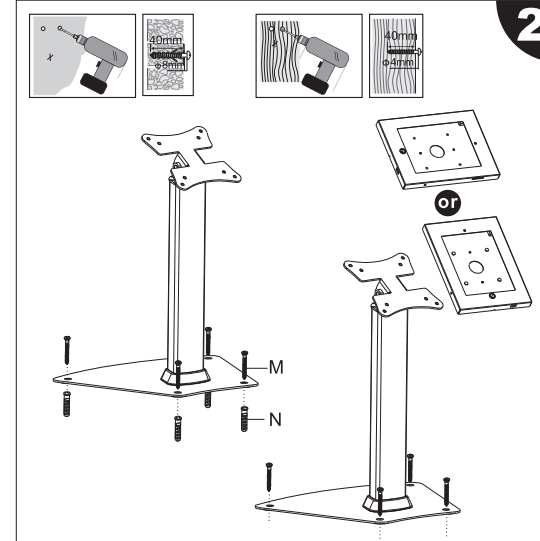

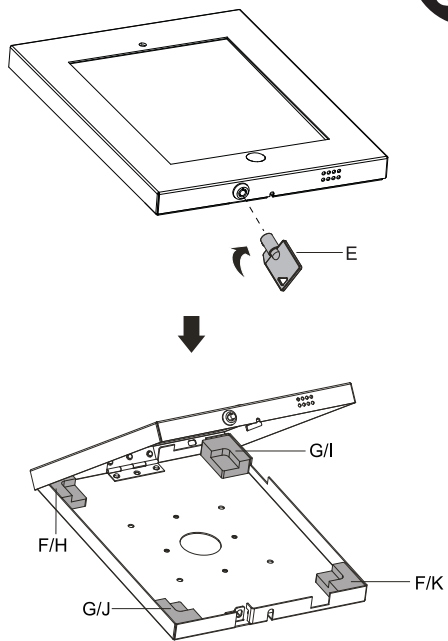
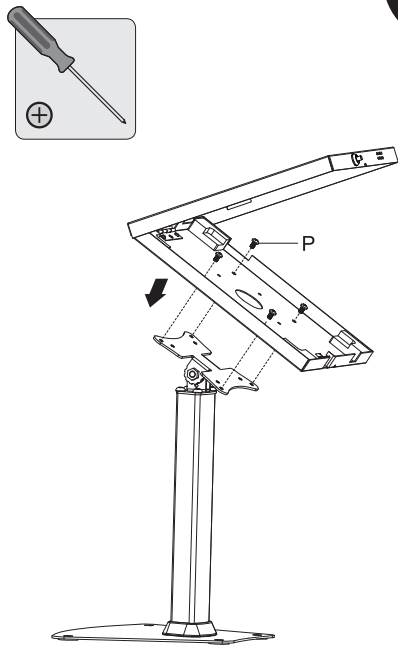
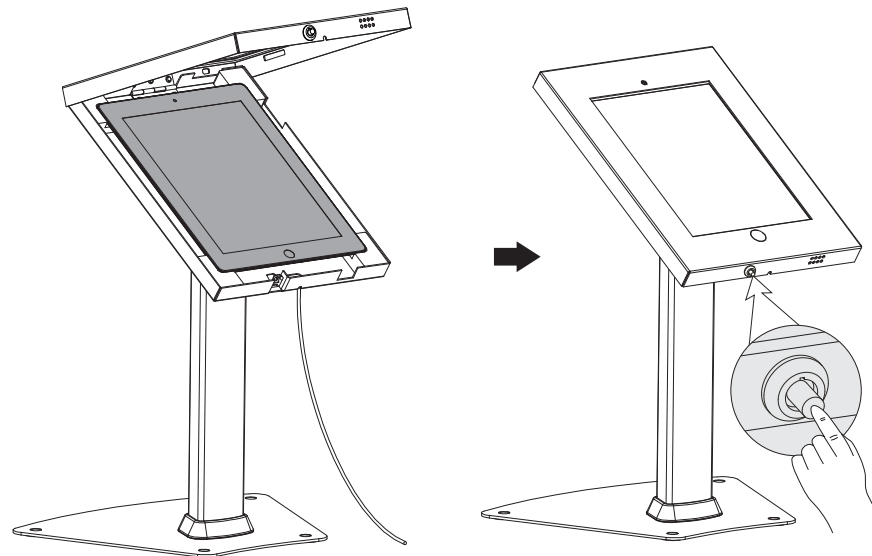
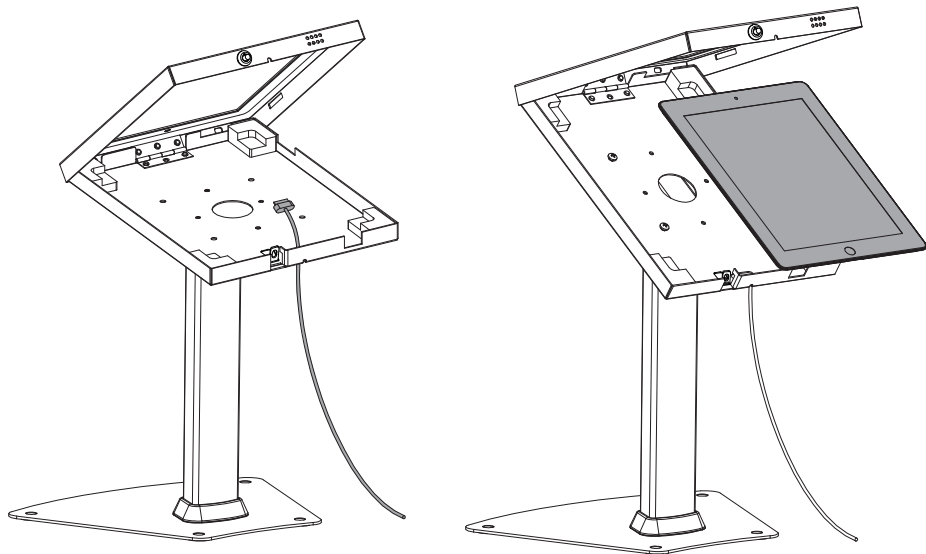
**3****4****6****5****7**