

User·Guide

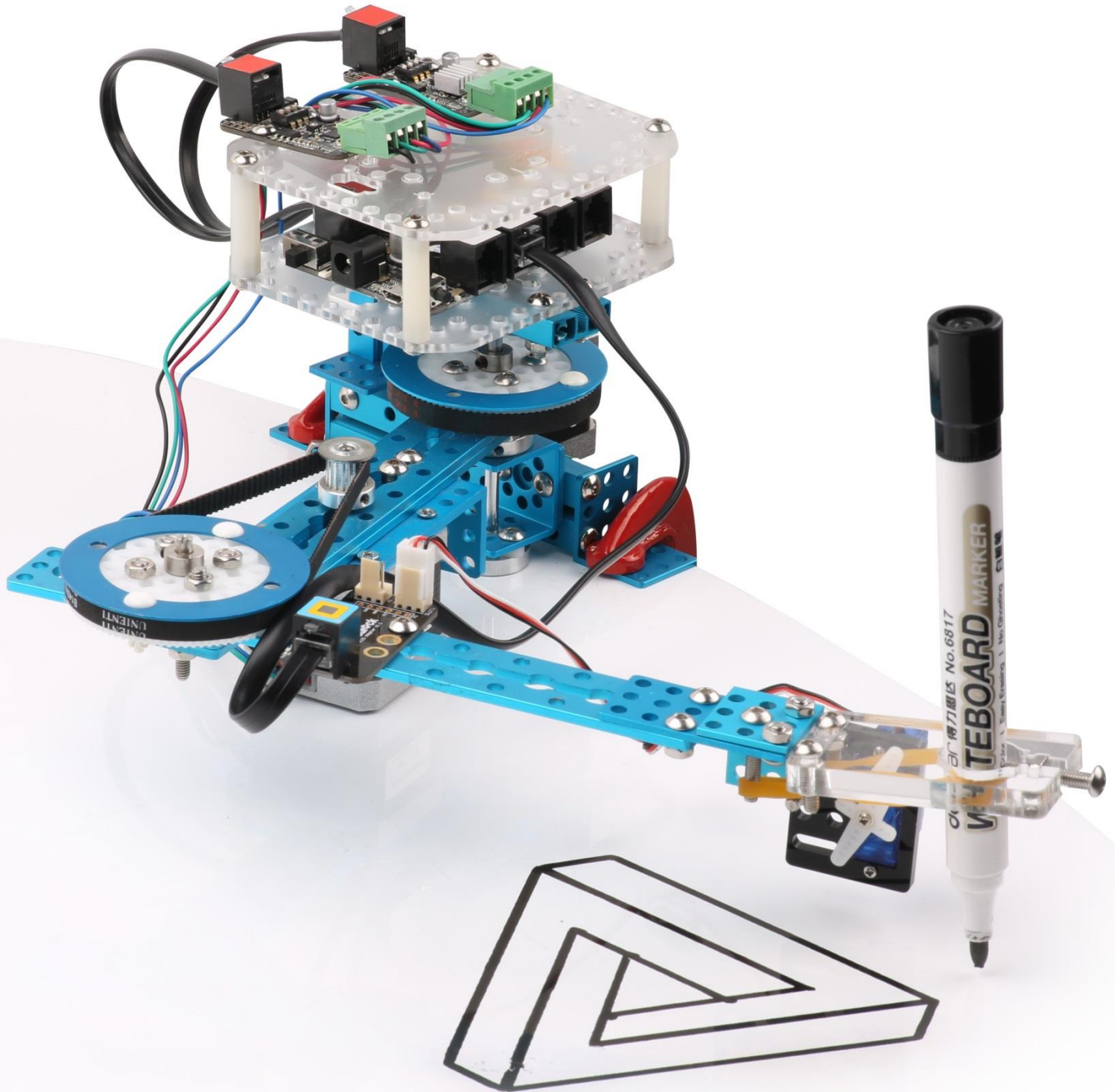



mScara



Contents

I、	Equipment necessary before	i
II、	mScara	2
III、	Mechanical assembly (see document mDrawBot instruction V1.1 20150704)	2
	Attachment Mechanical assembly steps for Laser Upgrade Pack.....	3
IV、	Recommended wiring diagram (Bluetooth communication for Bluetooth version) .	4
V、	Definition of electronic wiring for mScara standard and upgrade version.....	4
VI、	mDraw software.....	5
	1. Description of mDraw functions	5
	2. Software installation,	5
	3. Button function of main software interface	6
	4. Use of mScara.....	10
VII、	Example of completely using mDraw software.....	15
VIII、	See “How to use inkscape+corelDRAW software” for generation of SVG graph file. 17	
IX、	Please refer to mDrawBot FAQs - V1.3(English) for FAQs.	17
X、	Contact us:	17

I、 ⚠️ Equipment necessary before

1. Hardware:
 - ①.mDrawBot kit
 - ②. Assemble Instruction V1.1 20150704
2. Software:
 - a. Necessary software
 -  [mDraw](#)
 -  [Inksape](#)
 - B. Software possibly required
 -  [Arduino IDE](#)
 -  [Makeblock main board drive](#) (Note: If Mac OS system is used, click hyperlink to load and install the drive)
3. Download software and detained information package



<http://learn.makeblock.cc/mdrawbot/>

Hint 1

4 assembly modes are used for mDrawBot, the assembly of **all movable parts** has assembly accuracy requirement, install and finely adjust the robot strictly as required by the assembly description, **especially adjustment of shaft and rotating part, steering engine and rudder arm, machine levelness.**

Hint 2

The material object may differ from the picture provided in the specification, so the specification is only for reference, and specification and software may be changed without prior notice. Please assess the website for detailed change: <http://learn.makeblock.cc/mdrawbot/>

II、 mScara

Scara is the abbreviation of selective compliance assembly robot arm. It is a circular cylindrical coordinates drawing robot. mScara has optional two structure

- a. Standard mode The end is pen lift mechanism. (Pen lift mechanism)

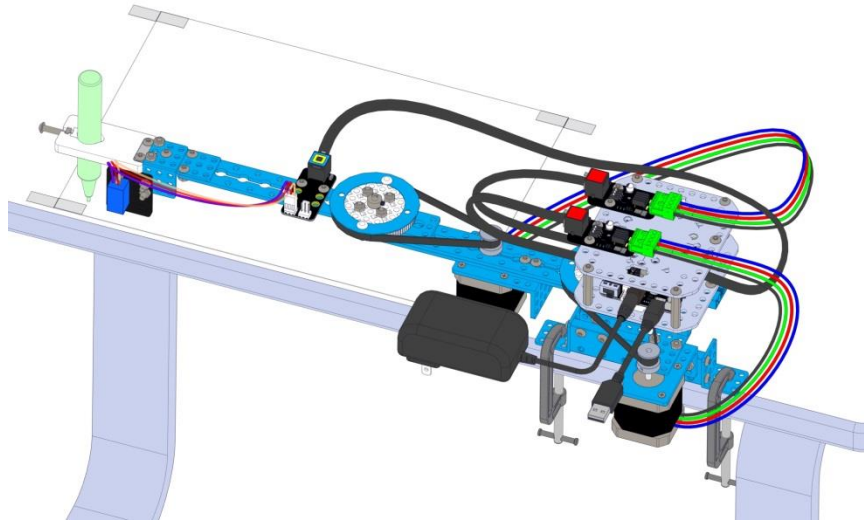

- b. Upgrade mode The end is 405nm, 500mW blue-violet diode laser

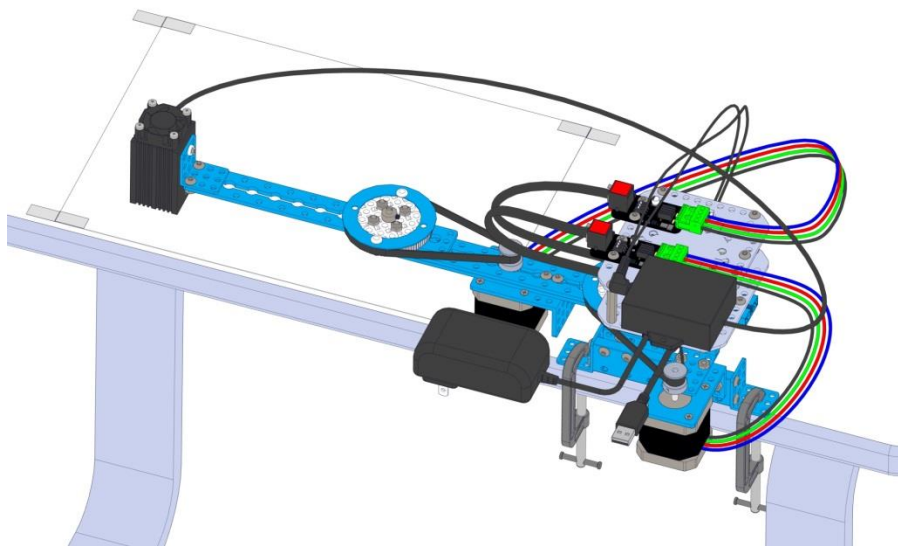

III、 Mechanical assembly (see document [mDrawBot instruction V1.1 20150704](#))

Attachment Mechanical assembly steps for Laser Upgrade Pack

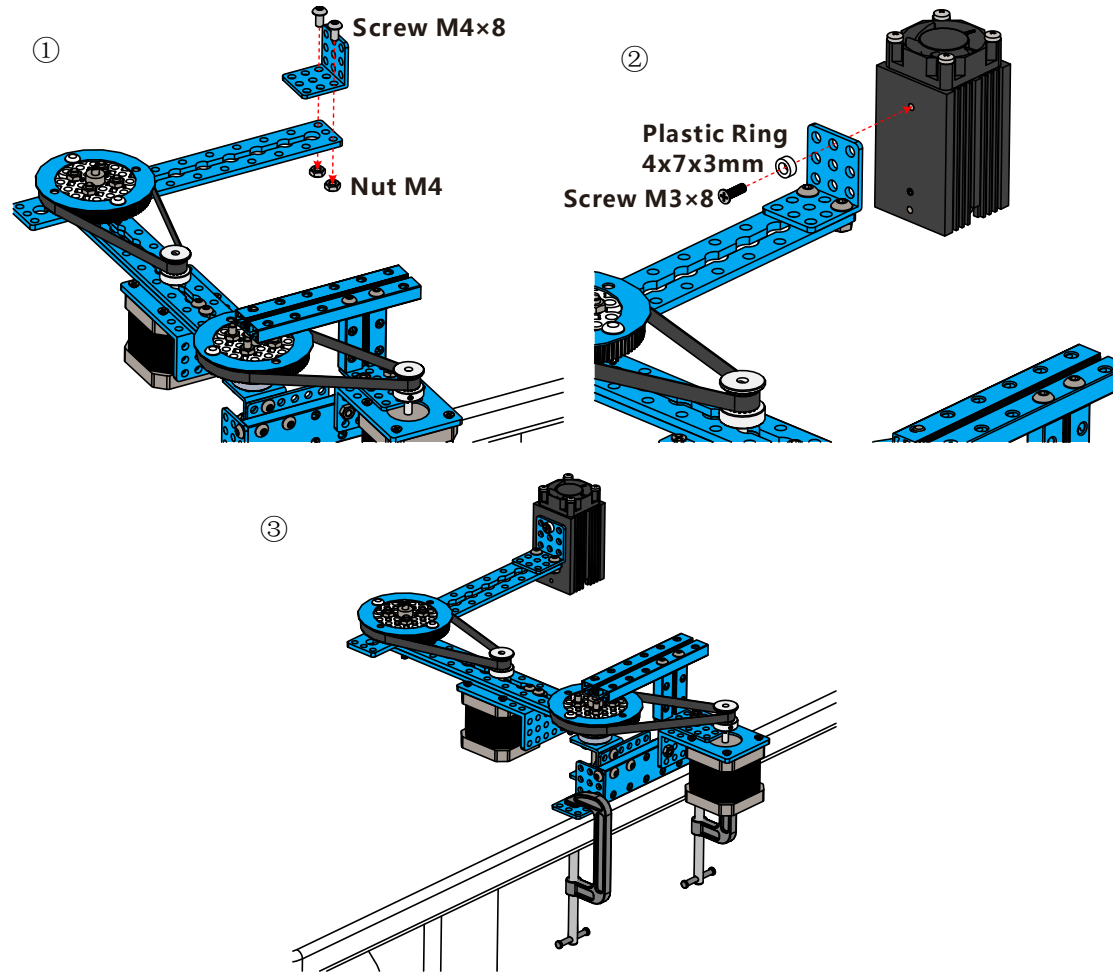

IV、 Recommended wiring diagram (Bluetooth communication for Bluetooth version)

(⚠ Note: When Bluetooth is used as serial port, connect Bluetooth with port 5 OF Makeblock Orion board.

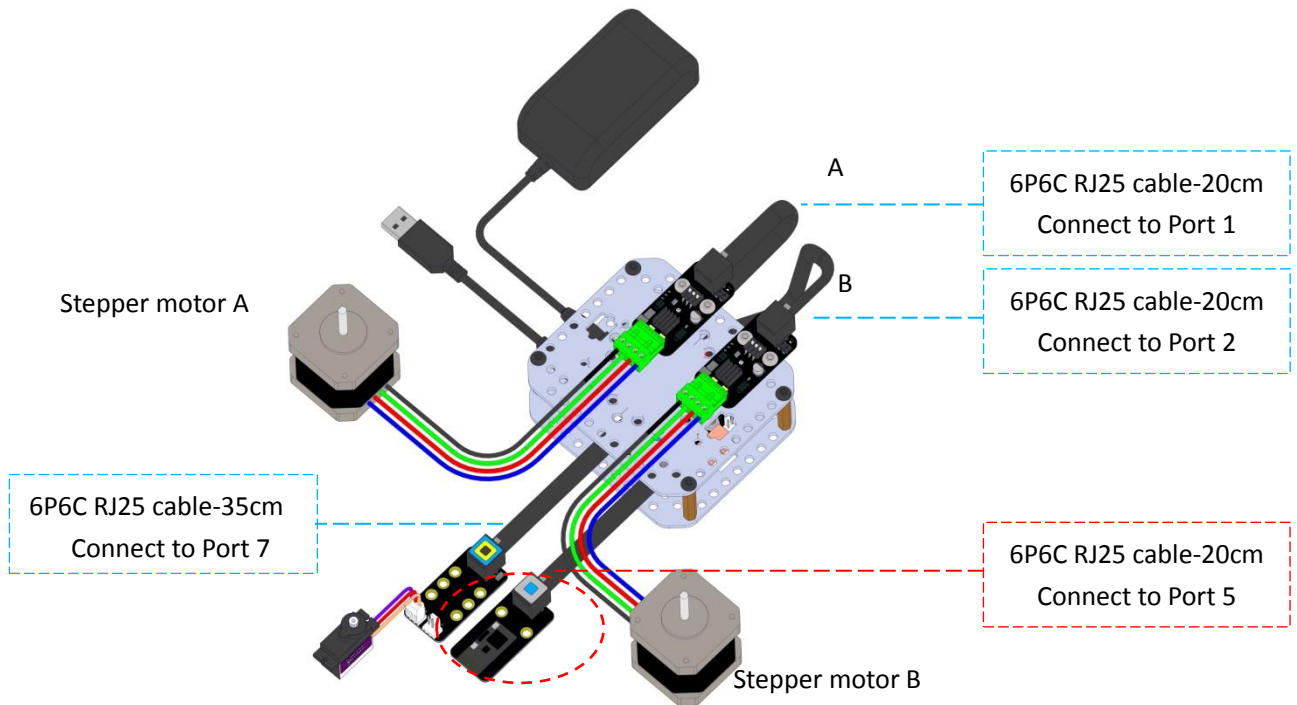

V、 Definition of electronic wiring for mScara standard and upgrade version

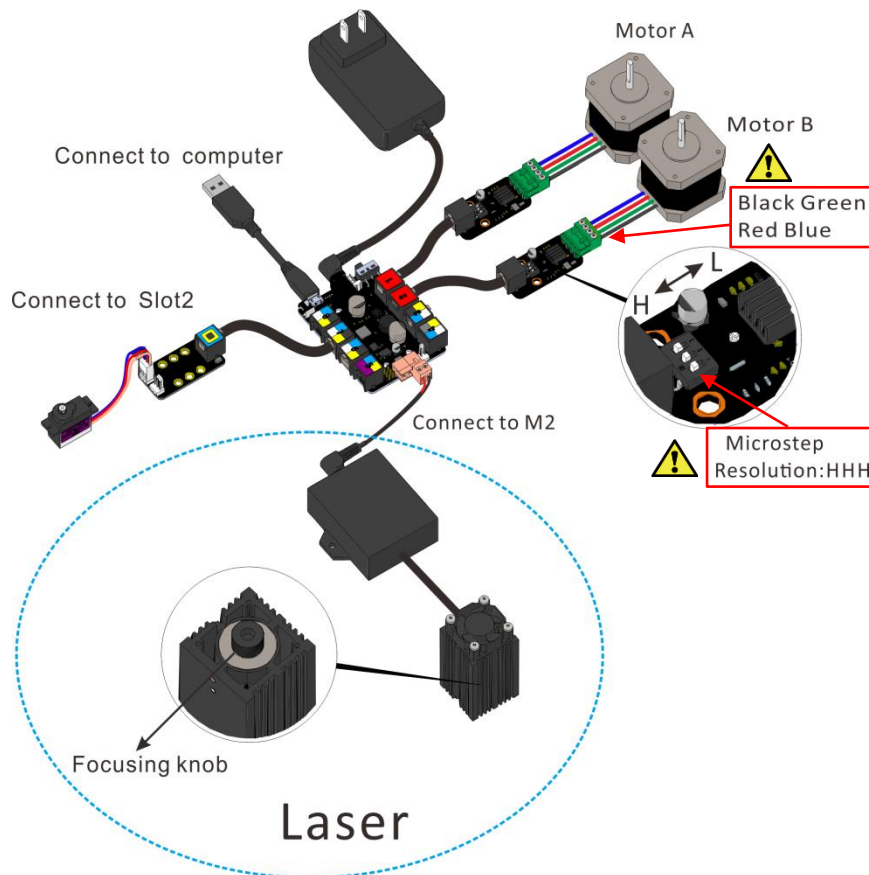

VI、 mDraw software

1. Description of mDraw functions

mDraw is open source cross-platform software produced by Makeblock and support Windows system, Mac system and Linux system, and perfectly supports four types of mDrawBot such as mSpider, mScara, mEggBot and mCar, and supports the steering engine mode and laser mode of Makeblock XY drawing robot kit V2.0.

Support SVG format, Change BMP to SVG

2. Software installation,

Unzip the downloaded file pack, find and double click the file as show in the figure.

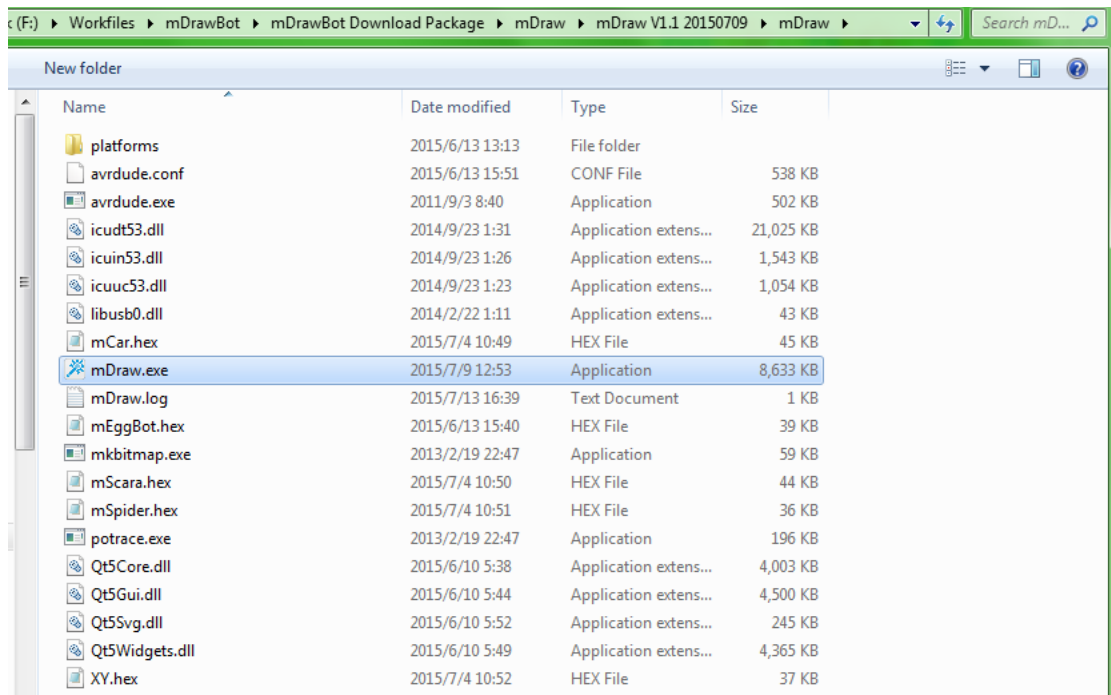

3. Button function of main software interface

(1) Main interface

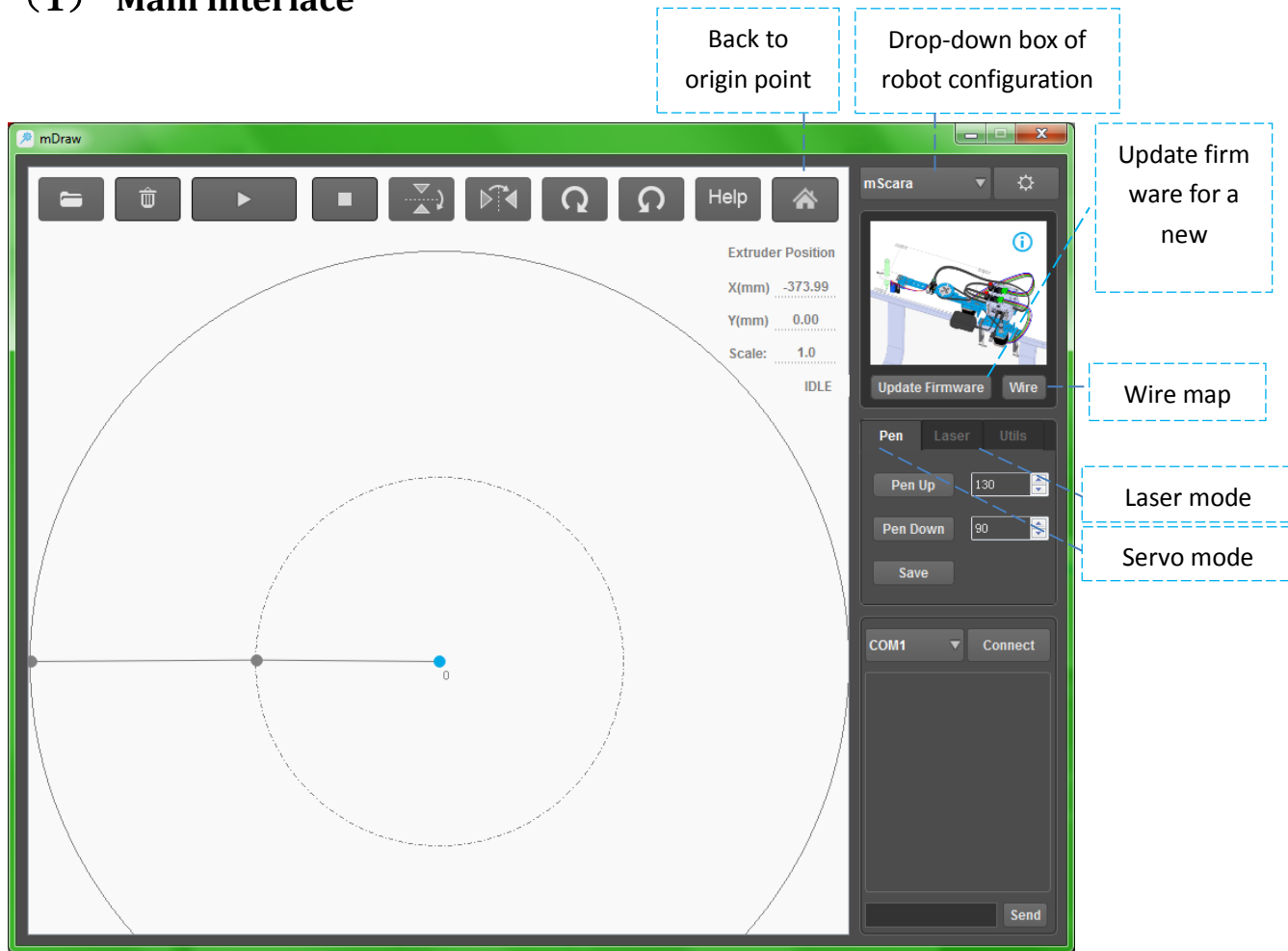

(2) Button function

- : Open the file
- : Delete SVG file
- : Begin/ suspend
- : Stop
- : Up and down mirror image
- : Left and right mirror image
- : Clockwise rotate at 90°
- : Anticlockwise rotate at 90°
- : Help link

: Machine returning to initial position

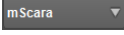
: Robot mode switching button: five modes such as mScara, mSpider, mEggBot, mCar,

XY

: Setting button, mainly used for setting arm length parameter, operation speed, and front and reverse rotation of motor

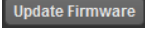
: Upgrade firmware button

: Electronic wiring diagram of robot

: Pen lift parameter setting

: Pen fall parameter setting

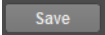
: Store pen lift and fall parameters on the main board chip

: Select serial port

: Serial port connecting button

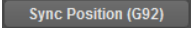
: Synchronous position

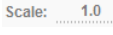
: Change drawing scale

(3) Function description of plot area

 a) After **double clicking** the main interface, the robot will move with the graph.

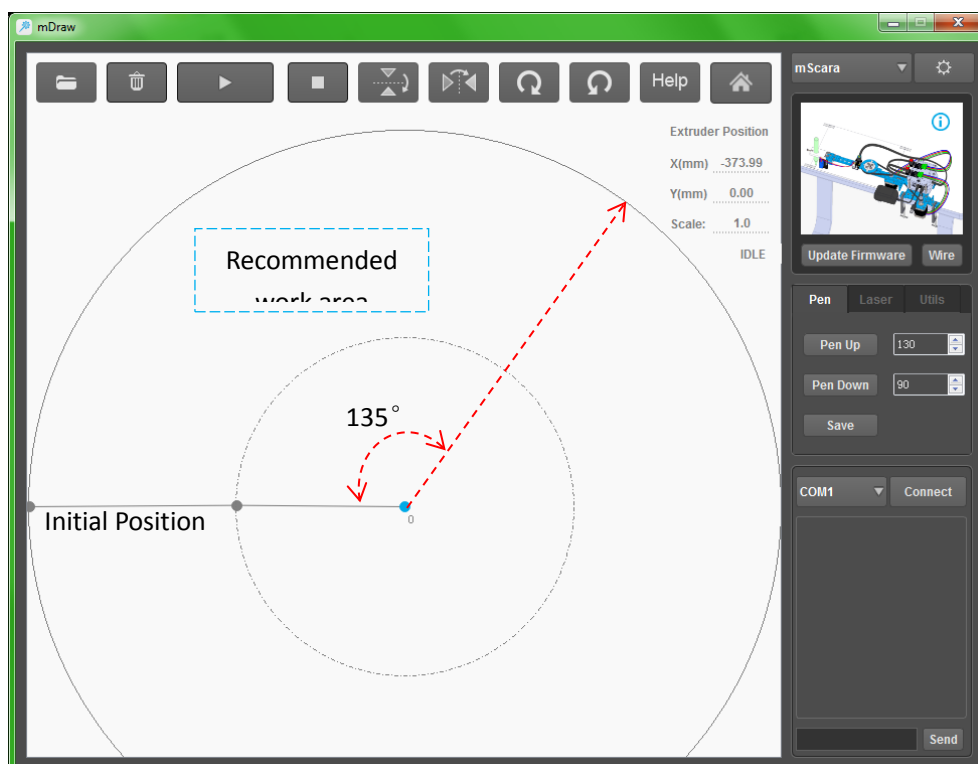

B). Drag the led SVG format to change the size and location of the SVG drawing, or change the drawing size by directly entering the digit on the low right of the graph.

c). While leading BMP file, the software automatically pop up SVG file change dialog box, and according to adjustment parameter, change the file to SVG format.

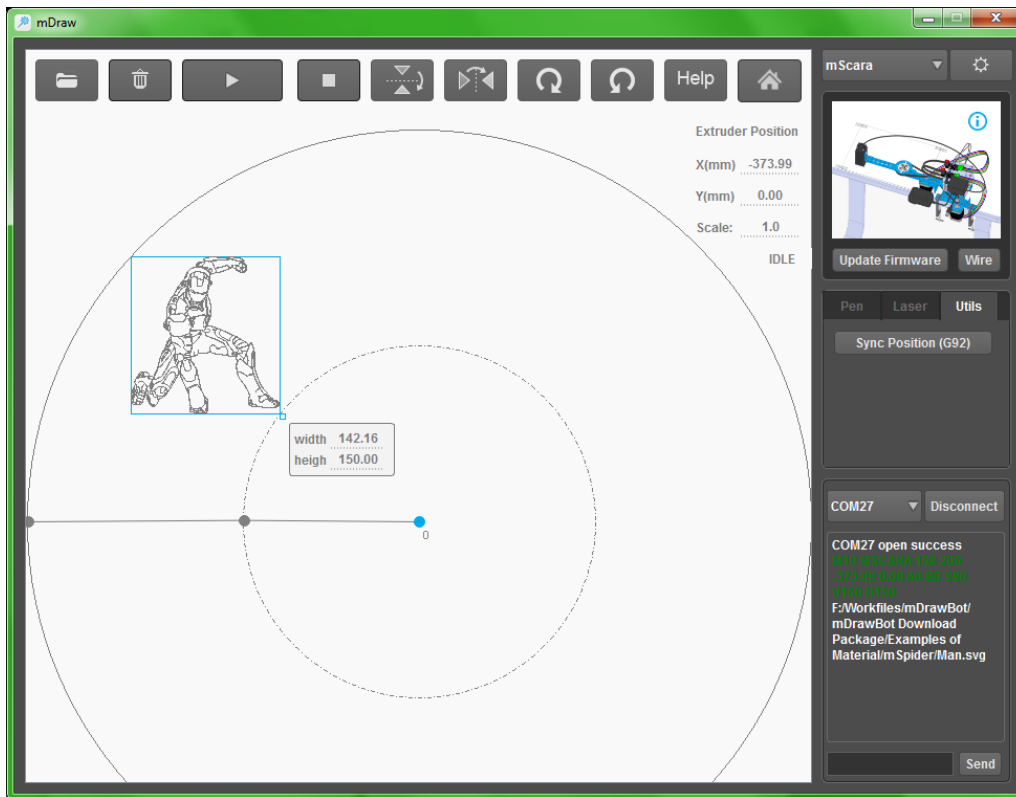

(4) Function description of setting area

a). Single click button to open the setting interface as shown in the following figure.

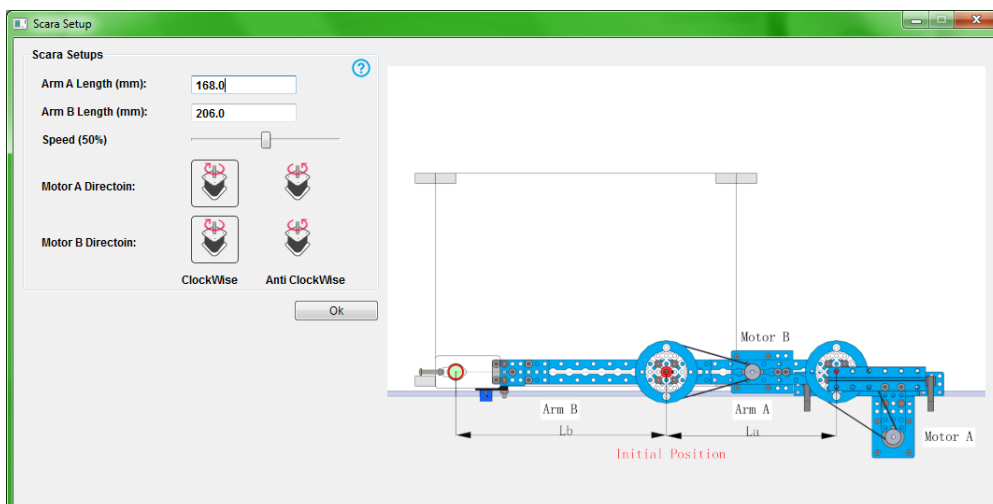

b).The length of arm A is determined value, and the length of the arm B is the installation size of mScara machine. **Fill after accurately measuring by paper rule or steel rule.**

c). The speed may be adjusted from 0 to 100%, and 50%-80% speed range is recommended for mScara. More than 80% is not recommended.

d). A button is arranged on the back to change the rotation direction of the stepping motor if the rotation direction is incorrect.

4. Use of mScara

(1) mScara (standard version)

- a) . Inspect and confirm that the wire connection is correct (Note: you may click **Wire** to inspect.). Connect USB with the computer ( Note: if Bluetooth is used, install the Bluetooth drive on the computer)
- b) . Select and connect correct COM port and click burning hardware (note: While the robot is switched to other drawing type, you are required to click Update Firmware to upgrade the firmware to ensure The robot can operate in new drawing type.

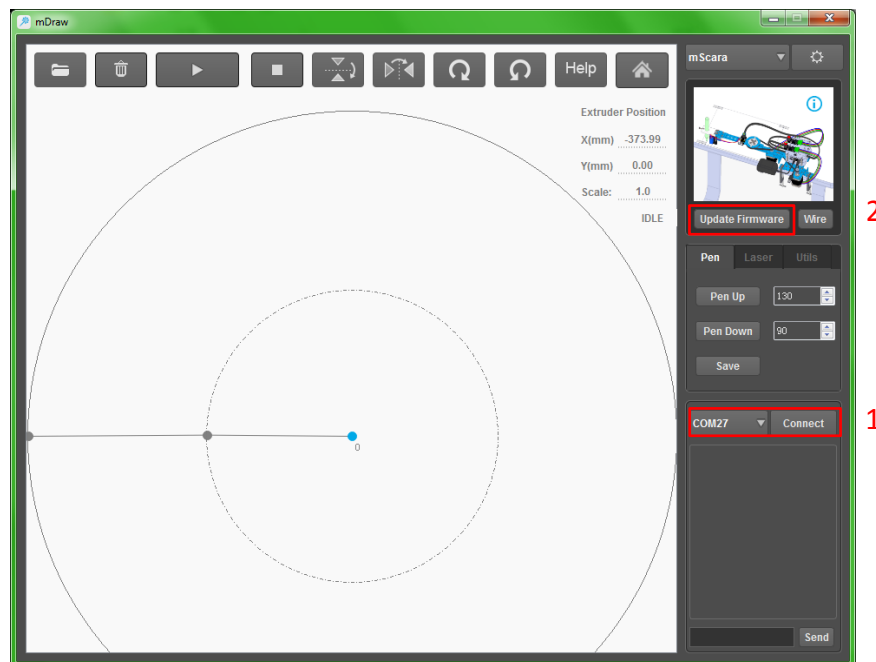

- c) .Click icon  to access the setting interface. Under general condition, default setting is used. Only when you change the length of the arms A and B of mScara, the value is changed. **Before use, measure the length of the arm B.** Click Ok to confirm.

 *Meaning of initial location top view and software parameter The speed is adjusted according to requirement.*

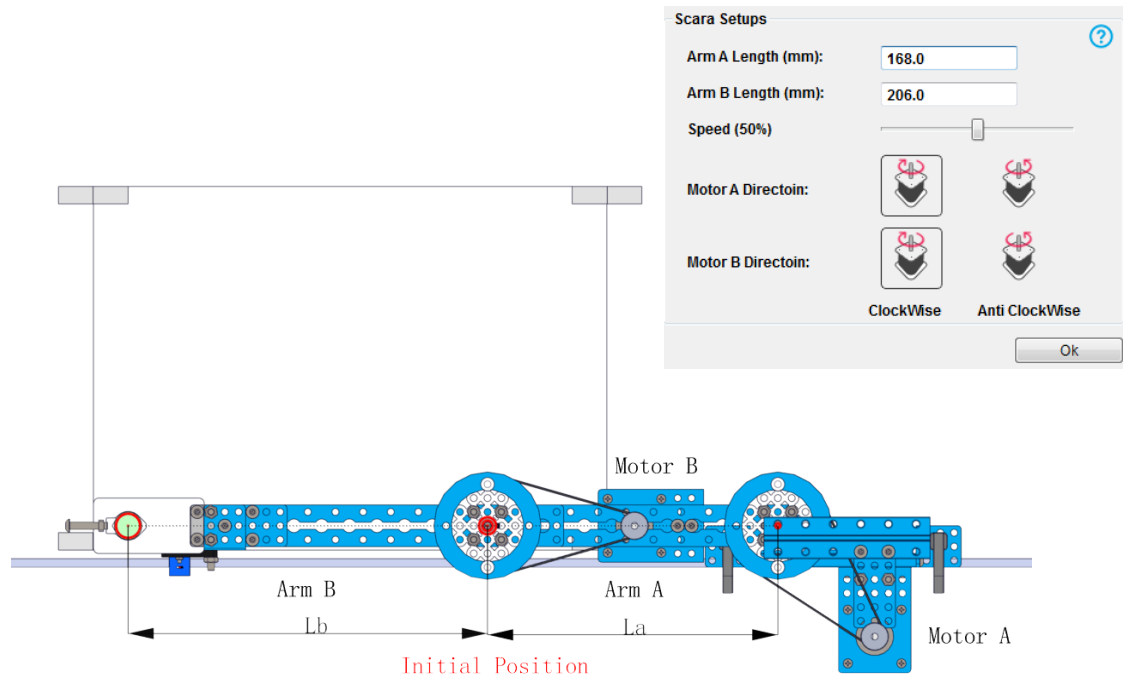

! Initial position axle side view, see (e) for the initial position corresponding to the software.

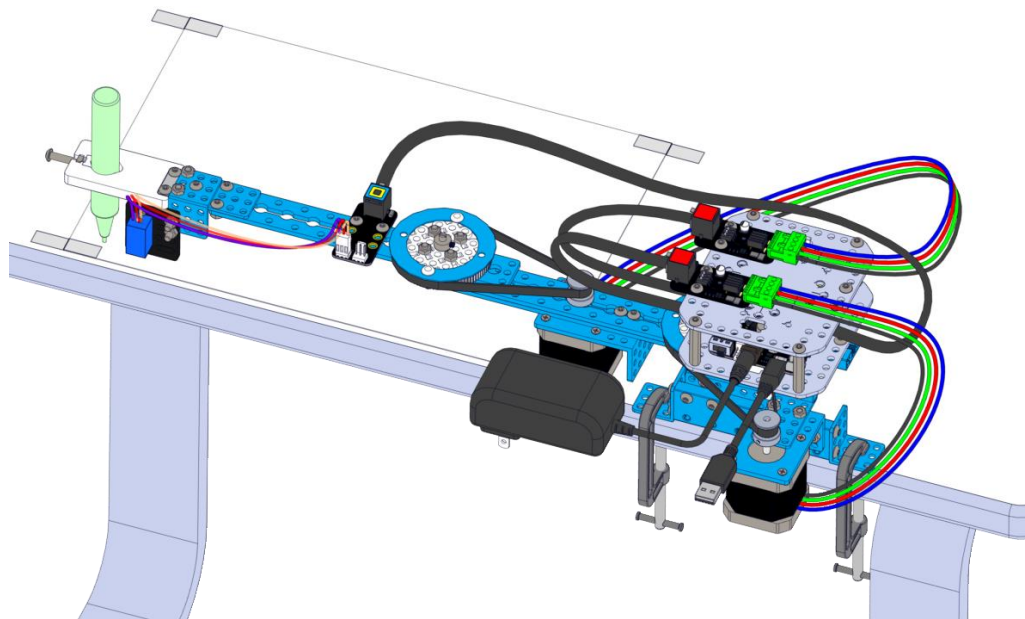

d) . Setting of steering engine pen lift and fall parameter

As shown in the figure, respectively enter the value by Pen up and Pen Down of the software, **click PenUp and PenDown**. When the following effect is observe and obtained, it is possible to set pen lift mechanism of the steering engine (note: If the rudder arm of the steering engine does not have the following angle, remove the rudder arm by a cross screwdriver to adjust installation angle, the rubber band is adjusted for degree of tightness according to requirement, and **pendown is subject to just contact with the paper**).

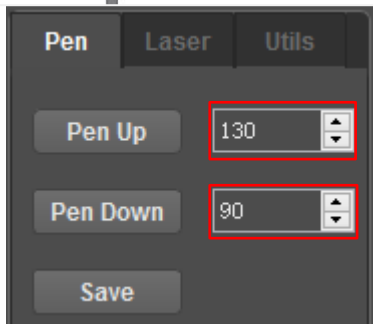
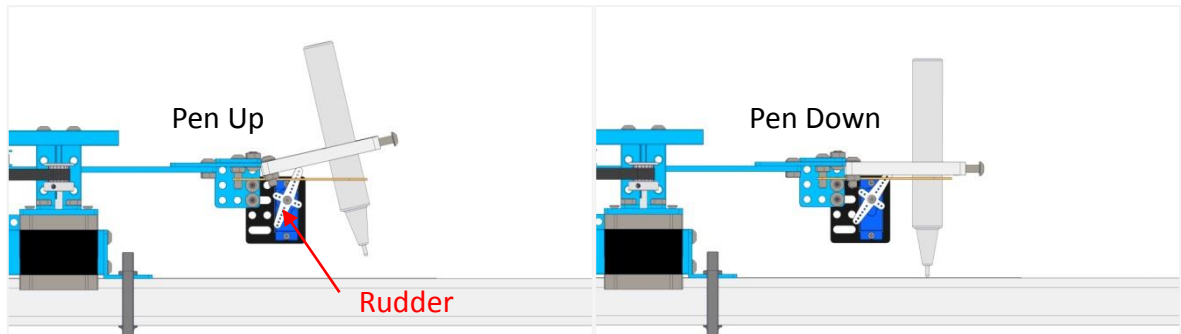

⚠ Note: Software default value is here, and the value is subject to the value set during debugging during use.

- e) . The led graph file is in 135° scope of **ring area** as much as possible, excess of the range may cause the drawn graph abnormal. Lead the following test graph, ...mDrawBot Download Package\Examples of Material\Test\Square.svg for effect test. ( If the graph is deformed or not closed, 1. Inspect whether La and Lb are correct. 2. Adjust the tightness of the screw, calibrate levelness and so on. 3. See FAQs for details)

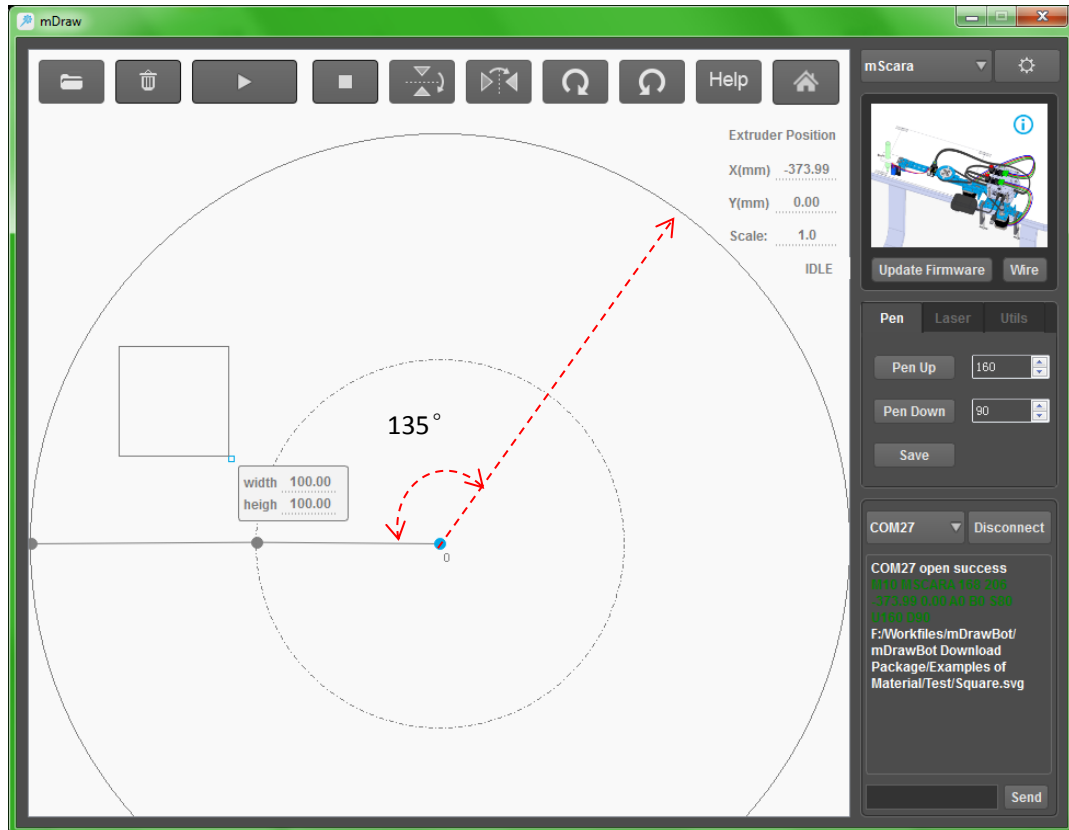

- f) . After setting the parameter, turn off the power switch on the main board, manually **reset** mScara to initial position, turn on the power switch on the main board, and click the button .

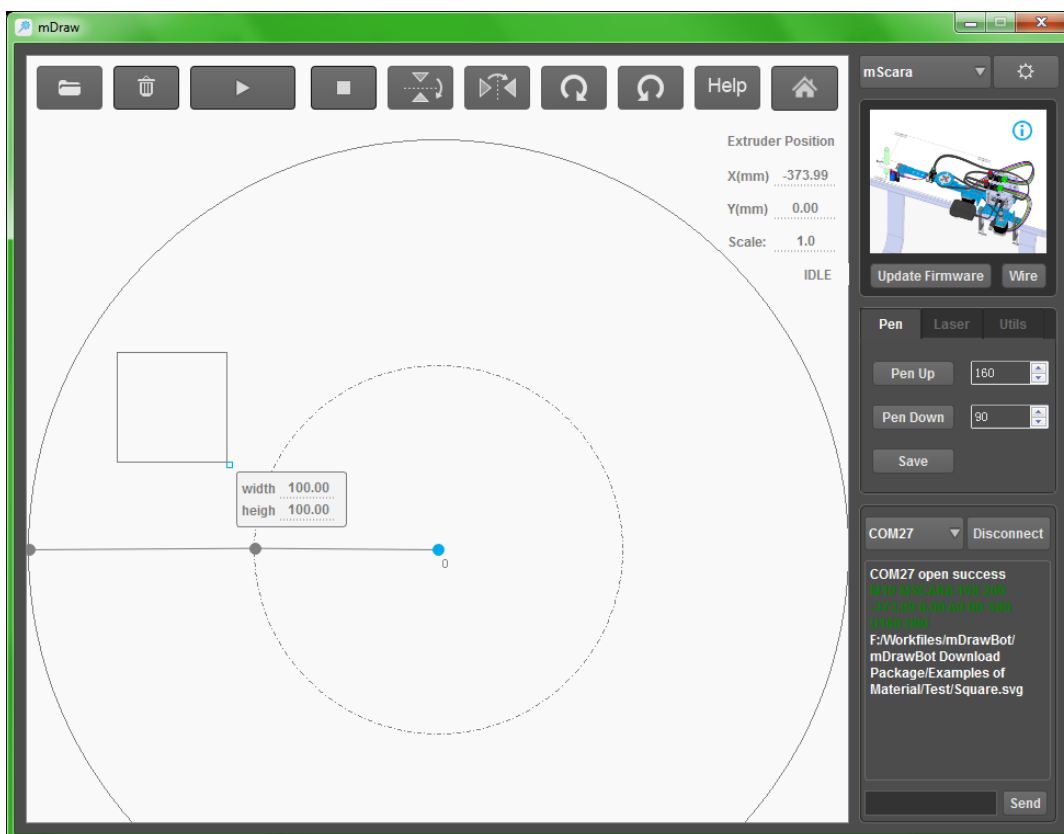
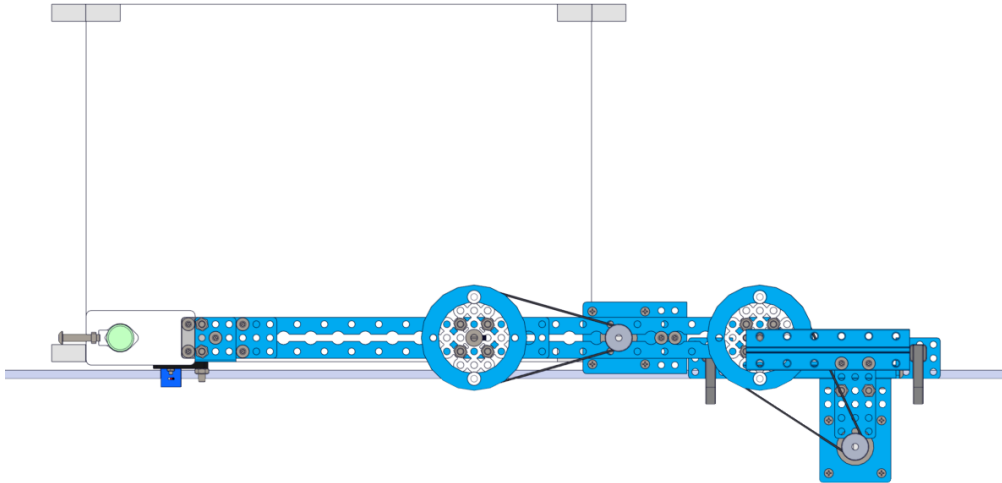

g) . Setting method or actual graph positioning.

As shown in the above figure, respectively **double click the left mouse button** around four top points of the drawing, observe the movement location of mScara to obtain actual preview and ensure the drawing location is the desirable location.

VII、 Example of completely using mDraw software

1. After the test is passed as shown above, mScara can operate smoothly. You may draw complex graph.
2. Automatically or manually reset mScara to the initial position. (⚠ ensure that the serial port is properly connected, the parameter of the pen lift mechanism is correctly set, and the power supply is properly connected).

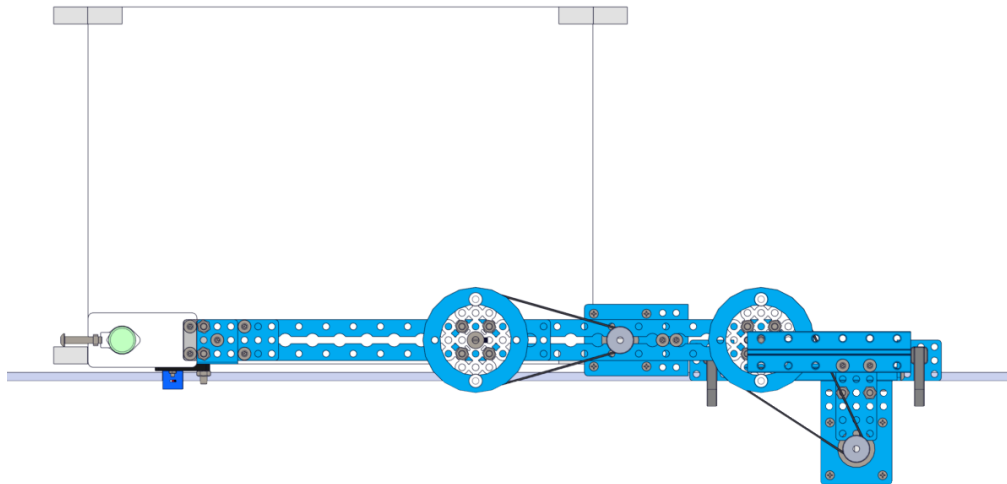

3. Load SVG graph, for example, \mDrawBot Download Package\Examples of Material\mSpider\Man.svg, as shown in the following figure.

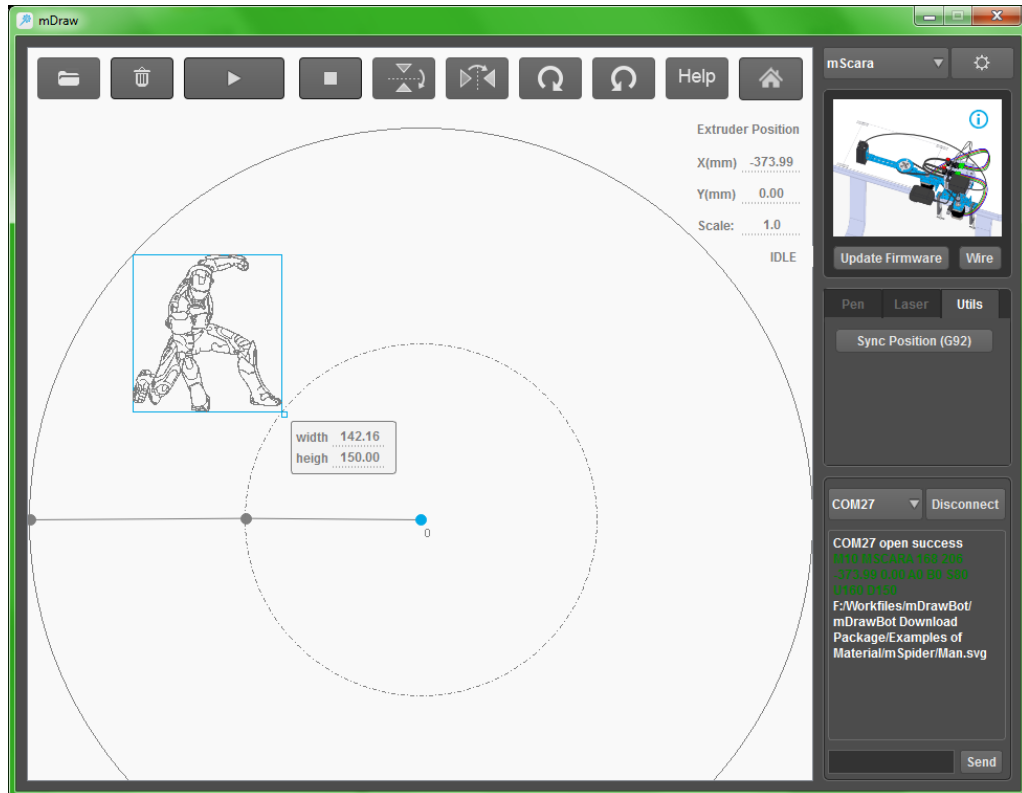

4. Click the button  of mDraw software mScara begins to operate. When the machine stops operation, the graph has been drawn. The drawing effect is shown below:

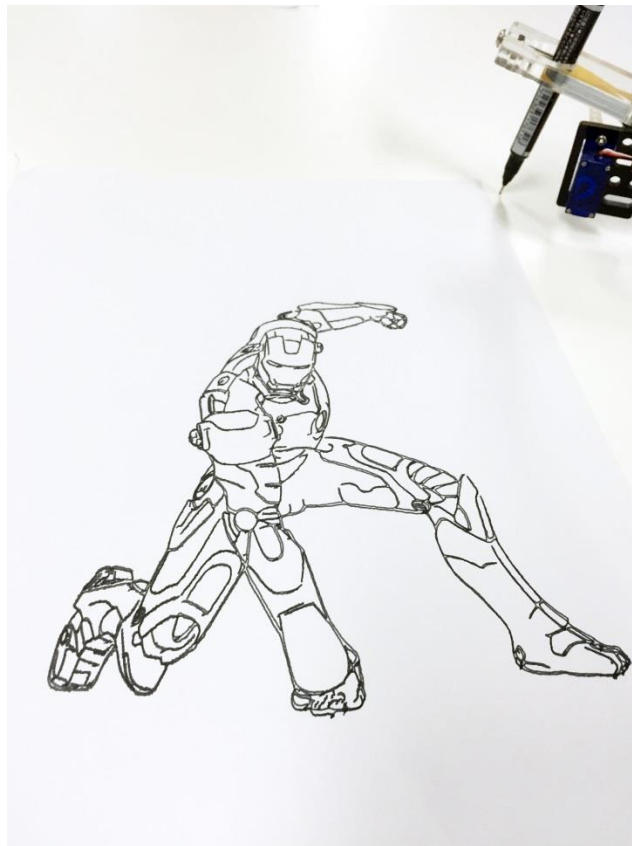

- VIII、 See “[How to use inkscape+corelDRAW software](#)” for generation of SVG graph file.
- IX、 Please refer to [mDrawBot FAQs - V1.3\(English\)](#) for FAQs.
- X、 Contact us:
- support@makeblock.cc
 - https://www.facebook.com/Makeblock?ref=br_tf
 - <https://plus.google.com/102486511775733872783/posts>
 - <https://twitter.com/Makeblock>

Makeblock ! Construct Your Dreams !