

MONOPRICE

Z-Wave Plus[®] Door/Window Sensor

P/N 24259

User's Manual

CONTENTS

SAFETY WARNINGS AND GUIDELINES	3
INTRODUCTION.....	3
FEATURES.....	4
CUSTOMER SERVICE.....	4
PACKAGE CONTENTS	4
PRODUCT DIAGRAM	5
INSTALLATION	5
INCLUSION.....	7
EXCLUSION.....	7
ASSOCIATION.....	8
RESETTING THE SENSOR	8
AUTO WAKE UP.....	8
LOW BATTERY ALARM.....	8
ADVANCED CONFIGURATION.....	9
Parameter 14 Enable/Disable BASIC SET Command.....	9
Parameter 15 Value of the BASIC SET	9
Parameter 32 Level of Low Battery	9
TECHNICAL SUPPORT	10
SPECIFICATIONS.....	10
REGULATORY COMPLIANCE.....	11
Radio Notice for FCC.....	11

SAFETY WARNINGS AND GUIDELINES

- This device is intended for indoor use only.
- Do not expose this device to water or moisture of any kind. Do not place drinks or other containers with moisture on or near the device. If moisture does get in or on the device, immediately remove the batteries and allow it to fully dry before reapplying power.
- Do not expose this device to excessively high temperatures. Do not place it in, on, or near heat sources, such as a fireplace, stove, radiator, etc. Do not leave it in direct sunlight.
- Clean using a soft, dry cloth only. Do not use chemical cleaners, solvents, or detergents. For stubborn deposits, moisten the cloth with warm water.
- This device has no user serviceable parts. Do not attempt to service or modify this device.

INTRODUCTION

Thank you for purchasing this Z-Wave Plus® Door/Window Sensor from Monoprice! This sensor is a wireless Z-Wave® enabled device and is fully compatible with any Z-Wave enabled network. Z-Wave is an interoperable, two-way RF mesh networking technology used for home automation and security. Every AC powered Z-Wave device acts as a signal repeater, so multiple devices result in more possible transmission routes, which helps eliminate RF "dead spots" in the network. Any Z-Wave enabled device displaying the Z-Wave logo can be used with Z-Wave devices from other manufacturers.

This Sensor mounts to a door or window, detects when it is opened or closed, and sends a Z-Wave trigger signal to the network. It also has a tamper-proof switch, which will trigger a Z-Wave signal when the sensor's cover is removed. These trigger signals can be used to activate various other devices and perform preprogrammed tasks. When the sensor is included into a secured Z-Wave network, all communications will be encrypted using AES encryption.

FEATURES

- Detects when a door or window is opened
- Tamper sensor sends an alert to the controller if the sensor is tampered with
- Uses the latest backward compatible revision of Z-Wave® technology
- Up to 1 year battery life
- Z-Wave Plus® provides 50% more power than previous generations
- Z-Wave Plus provides 67% improvement in transmission range
- Z-Wave Plus offers Plug-n-Play inclusion network wide

CUSTOMER SERVICE

The Monoprice Customer Service department is dedicated to ensuring that your ordering, purchasing, and delivery experience is second to none. If you have any problem with your order, please give us an opportunity to make it right. You can contact a Monoprice Customer Service representative through the Live Chat link on our website www.monoprice.com during normal business hours (Mon-Fri: 5am-7pm PT, Sat-Sun: 9am-6pm PT) or via email at support@monoprice.com

PACKAGE CONTENTS

After receiving the product, please inventory the contents to ensure you have all the proper parts, as listed below. If anything is missing or damaged, please contact Monoprice Customer Service for a replacement.

1x Z-Wave Plus® Door/Window Sensor

1x Magnet

2x Adhesive Tape

4x Mounting Screws

1x User's Manual

PRODUCT DIAGRAM

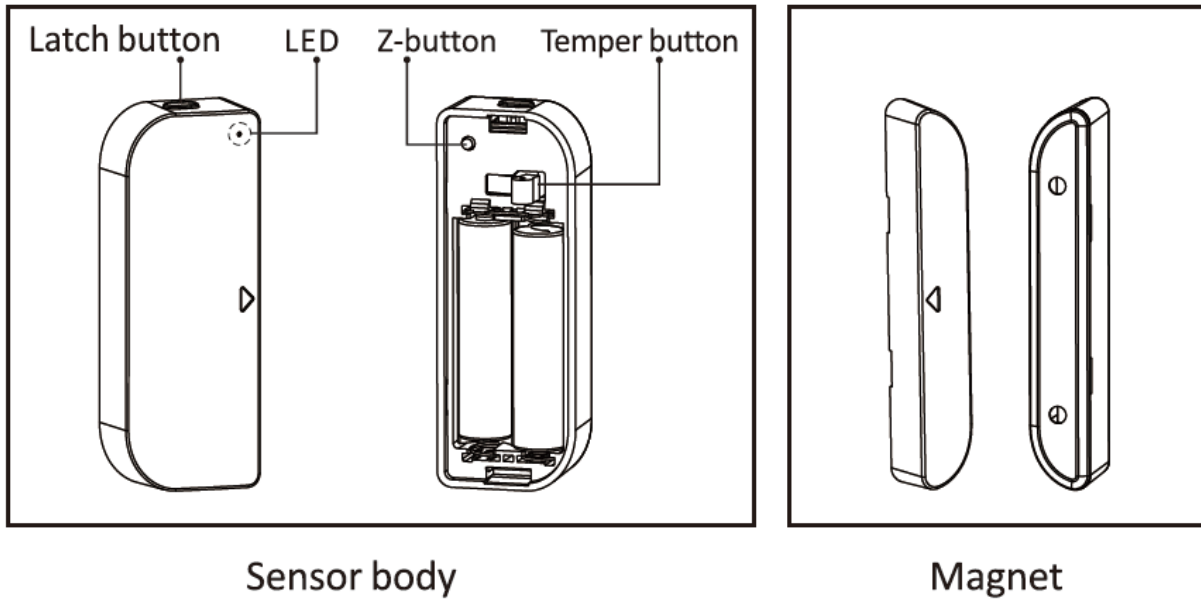

INSTALLATION

Note: If you are installing a complete Z-Wave® system for the first time, please refer to the installation guide of your Z-Wave Interface Controller before installing this sensor.

1. Determine the mounting location. Note that the arrow on the magnet should be situated next to the arrow on the sensor with no more than 0.4" (10mm) gap between the sensor and the magnet. Use a pencil to mark the locations. Ensure that the surfaces inside the marked locations are clean and free of dust and finger oils.

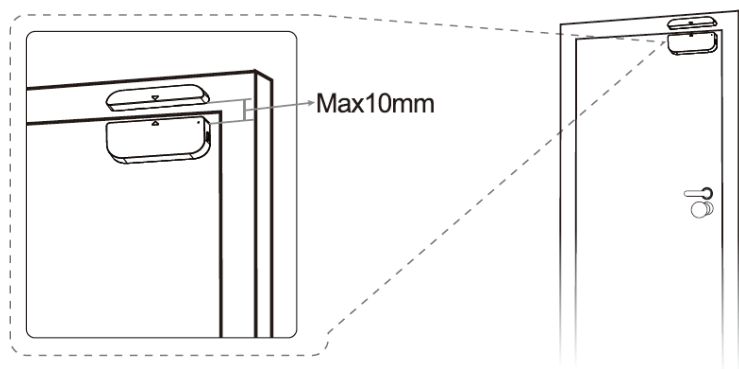
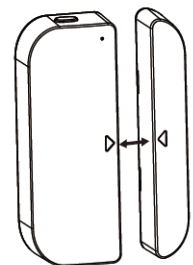

- Using a small flat-head screwdriver, remove the cover from the magnet as shown in the image to the right.

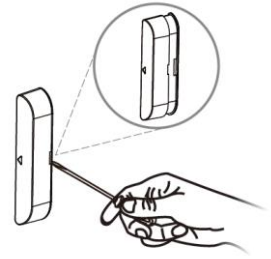

- Press the latch button on the sensor and remove the sensor back plate from the main sensor body.

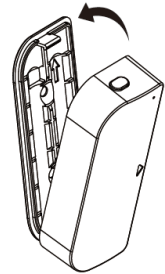

- If you will be mounting the magnet with screws, use two of the provided screws to secure the magnet back to the wall, window, window frame, door, or door frame at the previously marked location. Otherwise, peel the protective film from one side of one of the included adhesive tape pieces and attach it to the back of the magnet back plate, then remove the other protective film and secure the magnet and tape to the wall, window, window frame, door, or door frame.

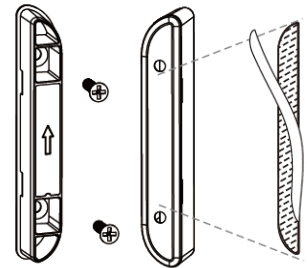

- Reinstall the cover on the magnet body.

- Use two of the supplied screws to attach the sensor back plate to the wall, window, window frame, door, or door frame the marked location. Alternatively, peel the protective film from one side of one of the included adhesive tape pieces and attach it to the back of the sensor back

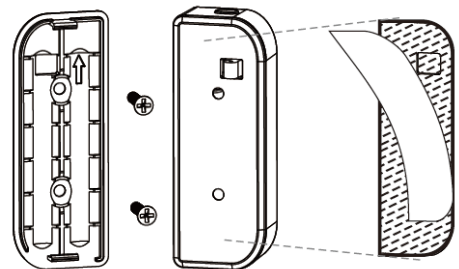

plate, then remove the other protective film and secure the sensor back plate and tape to the wall, window, window frame, door, or door frame.

- Reinstall the main sensor body onto the sensor back plate.

INCLUSION

Perform the following steps to "include" the sensor into your Z-Wave® network.

1. Press the latch button on the sensor and remove the sensor back plate from the main sensor body.
2. Insert two AAA batteries into the battery compartment.
3. Position your Z-Wave controller within 3 feet (1 meter) of the sensor. Following the instructions that came with your controller, put it into "inclusion" mode.
4. If you want to include the sensor as a non-secure device, rapidly press the Z-button three times. If you want to include the sensor as a secure device, press and hold the Z-button for 3 seconds.
5. If the inclusion is successful, the LED will blink for about 5 seconds, then will stay illuminated for an additional 3 seconds. If it was unsuccessful, the LED will blink for about 5 seconds, then will extinguish.
6. Replace the main sensor body onto the sensor back plate.

EXCLUSION

If you wish to remove the sensor from your network, you will need to "exclude" it.

1. Press the latch button on the sensor and remove the sensor back plate from the main sensor body.
2. Insert two AAA batteries into the battery compartment.
3. Following the instructions that came with your Z-Wave® Controller, put it into "exclude" mode.
4. Rapidly press the Z-button three times.
5. If the exclusion is successful, the LED will extinguish within 1 second. If it was not successful, the LED will blink for 5 seconds.

ASSOCIATION

This sensor can be associated with other Z-Wave® devices, such as smart switches, smart dimmers, etc. It supports two association groupings and up to five associated nodes.

- Group 1 reports the status of the Door/Window Sensor, the battery level, and the tamper button status.
- Group 2 is assigned to the Door/Window Sensor **BASIC SET** command.

RESETTING THE SENSOR

To reset the sensor, press and hold the Z-button for about 20 seconds. The LED will change from steadily illuminated to blinking then back to steadily illuminated, indicating that the reset operation was successful. Note that this should only be done if the primary Z-Wave controller is missing or otherwise inoperable.

AUTO WAKE UP

The sensor is normally asleep and only "wakes up" when the magnet is separated from the sensor body. However, it can be set to periodically "wake up" to communicate with any assigned devices, update parameters, update the firmware, or detect the battery level. Use the **WAKE UP** command class to set the auto wake up interval. The interval can be set to any value between 0 and 2678400 seconds, with 0 being the default. When set to 0, the sensor will only wake up when the magnet is separated from the sensor body.

LOW BATTERY ALARM

The sensor will send a battery report to the lifeline group whenever the Z-button is pressed during sleep mode. If the battery level is less than the configured value, the sensor will notify the lifeline nodes.

ADVANCED CONFIGURATION

Parameter 14 Enable/Disable BASIC SET Command

The sensor can send the **BASIC SET** command to nodes associated with group 2.

0 = Disable

1 = Enable

Parameter Size: **1 byte**

Default Setting: **0**

Parameter 15 Value of the BASIC SET

The **BASIC SET** value sent by the sensor when the magnet is triggered can be reversed from its default state.

0 = Sends the **BASIC SET VALUE 255** to nodes associated with group 2 when the door/window is opened and sends the **BASIC SET VALUE 0** to nodes associated with group 2 when the door/window is closed.

1 = Sends the **BASIC SET VALUE 0** to nodes associated with group 2 when the door/window is opened and sends the **BASIC SET VALUE 255** to nodes associated with group 2 when the door/window is closed.

Parameter Size: **1 byte**

Default Setting: **0**

Parameter 32 Level of Low Battery

You can change the battery level at which the sensor sends a low battery alarm.

Available Settings: **10-50 (10% - 50%)**

Default Setting: **20 (20%)**

Parameter Size: **1 byte**

TECHNICAL SUPPORT

Monoprice is pleased to provide free, live, online technical support to assist you with any questions you may have about installation, setup, troubleshooting, or product recommendations. If you ever need assistance with your new product, please come online to talk to one of our friendly and knowledgeable Tech Support Associates. Technical support is available through the online chat button on our website (www.monoprice.com) during regular business hours, 7 days a week. You can also get assistance through email by sending a message to tech@monoprice.com

SPECIFICATIONS

Model	24259
Radio Protocol	Z-Wave®
Radio Frequency	908.42 MHz
Power Source	2x AAA batteries (available separately)
Operating Current	about 60mA
Standby Current	about 30µA
Outdoor Range	> 328 feet (100 meters)
Indoor Range	about 98 feet (30 meters)
Operating Temperature	+32 ~ +104°F (0 ~ +40°C)
Storage Temperature	+14 ~ +122°F (-10 ~ +50°C)
Storage Humidity	0 ~ 90% RH, non-condensing
Sensor Dimensions	3.0" x 1.1" x 0.7" (75 x 28 x 18 mm)
Magnet Dimensions	3.0" x 0.5" x 0.7" (75 x 12 x 18 mm)

REGULATORY COMPLIANCE



Radio Notice for FCC

Caution

This FCC Part 15 radio device operates on a non-interference basis with other devices operating at this frequency. Any changes or modification to said product not expressly approved by Monoprice, including the use of non-approved antennas, could void the user's authority to operate this device.

This device complies with Part 15 of the FCC Rules. Operation is subject to the following two conditions: (1) this device may not cause harmful interference, and (2) this device must accept any interference received, including interference that may cause undesired operation.

Z-Wave and Z-Wave Plus are registered trademarks of Sigma Designs and its subsidiaries in the United States and other countries.