

# Instruction 1

## 2-sided page

### Quick Mount LCD Monitor / TV Kit

Wall Plate

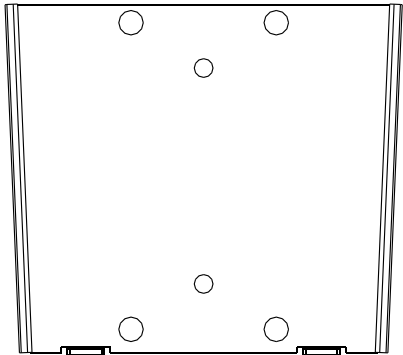

Use the 2 1/4" wood screws, mount the wall plate to wall stud or use enclosed sheet rock mollies



Note: Bracket is intended for use on LCD monitors up to 66lbs

LCD TV / Monitor Plate

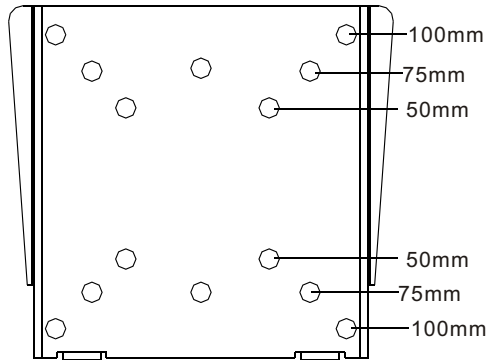

Use the 1/2" bolts, mount the monitor plate to back of monitor, (Note corners holes to accommodate both 75mm or 100mm VESA systems)



Use the 1/4" bolts to lock and secure your monitor in place



VESA® is a registered Trademark of the Video Electronics Standards Association

**Front**

### AS Easy as 1,2,3!

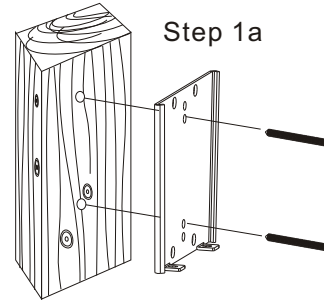

Using the 2 1/4" wood screws, mount the wall plate to **wall stud**

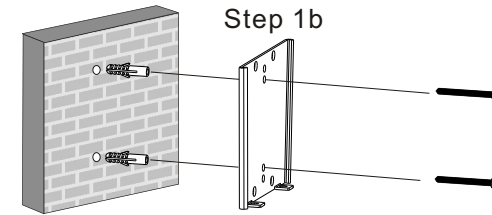

Pre-drill these mounting holes with a 8mm masonry bit to an least 50mm in depth. Using the 2 1/4" wood screws and concrete anchor mount the wall plate to **wall**

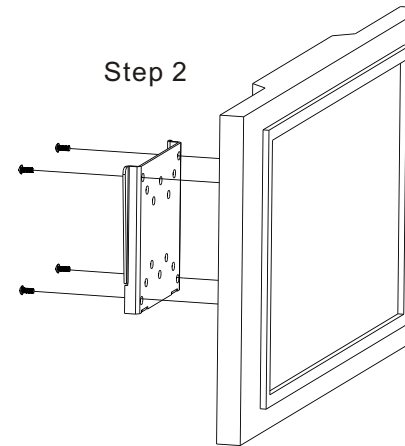

Using the 1/2" bolts, mount the monitor plate to back monitor, Depending on your monitor, Use the 75mm or 100mm pre-drilled holes

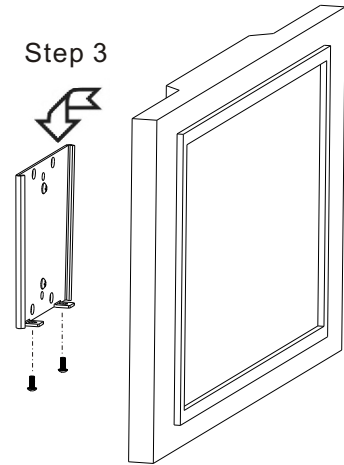

Simply slip your monitor onto your wall mount, and secure with 1/4" locking bolts from below, and you are finished! Enjoy!

VESA® is a registered Trademark of the Video Electronics Standards Association

**Back**