



SB-300 Dolby Atmos[®] Soundbar



P/N 42033

User's Manual

CONTENTS

SAFETY WARNINGS AND GUIDELINES.....	4
INTRODUCTION.....	6
FEATURES	6
CUSTOMER SERVICE.....	7
PACKAGE CONTENTS	7
PRODUCT OVERVIEW.....	8
Overall.....	8
Top Panel.....	9
Rear Panel.....	9
Remote Control.....	10
INSTALLATION.....	11
Safety Warning.....	11
Positioning	12
Wall Mounting.....	12
Remote Control.....	14
SOUNDBAR ENHANCED FEATURES.....	14
Dolby Atmos.....	14
eARC/ARC.....	15
CONNECTIONS	16
HDMI OUT	16
HDMI IN 1/HDMI IN 2.....	17
OPTICAL.....	18
COAXIAL	19

AUX.....	20
Power.....	20
POWER SAVING.....	21
BLUETOOTH OPERATION.....	21
USB OPERATION.....	23
TROUBLESHOOTING.....	24
TECHNICAL SUPPORT.....	26
SPECIFICATIONS.....	26
REGULATORY COMPLIANCE.....	27
Notice for FCC.....	27
RF Exposure Statement for FCC.....	28
Notice for Industry Canada.....	29
RF Exposure Statement for Industry Canada.....	29

SAFETY WARNINGS AND GUIDELINES

Please read this entire manual before using this device, paying extra attention to these safety warnings and guidelines. Please keep this manual in a safe place for future reference.

- This device is intended for indoor use only.
- Do not expose this device to water or moisture of any kind. Do not place drinks or other containers with moisture on or near the device. If moisture does get in or on the device, immediately remove it from its power source and allow it to fully dry before reapplying power.
- Do not touch the device, the power cord, or any other connected cables with wet hands.
- If operating this speaker in a humid environment, ensure that no condensation occurs. Condensation could cause damage to the speaker cone and could cause a short in the amplifier, which in turn could cause fire or severe electric shock.
- Do not install this device on an unstable surface where it could fall and cause either personal injury or damage to the device and/or other equipment.
- Do not expose this device to excessive vibration, extreme force, shock, or fluctuations in temperature or humidity.
- Avoid prolonged exposure to excessive volume levels, which could cause hearing damage. Reduce the volume to minimum before using this soundbar, then increase the volume to a comfortable listening level.
- Do not expose this device to excessively high temperatures. Do not place it in, on, or near a heat source, such as a fireplace, stove, radiator, etc. Do not leave it in direct sunlight.
- Do not place or install this device in an area where it can be exposed to excessive amounts of dust, humidity, oil, smoke, or combustible vapors.

- Prior to operation, check the unit and power cord for physical damage. Do not use if physical damage has occurred.
- Before plugging the unit into a power outlet, ensure that the outlet provides the same type and level of power required by the device.
- Unplug this device from the power source when not in use.
- Take care to prevent damage to the power cord. Do not allow it to become crimped, pinched, walked on, or become tangled with other cords. Ensure that the power cord does not present a tripping hazard.
- Never unplug the unit by pulling on the power cord. Always grasp the connector head or adapter body.
- Ensure that power is turned off and disconnected before making any electrical connections.
- Remove the batteries from the controller if it will go unused for a lengthy period of time.
- Do not mix new and old batteries or batteries of different types.
- Do not mix alkaline, standard, or rechargeable batteries with this product.
- Clean using a soft, dry cloth only. Do not use chemical cleaners, solvents, or detergents. For stubborn deposits, moisten the cloth with warm water.
- This device has no user serviceable parts. Do not attempt to open, service, or modify this device.

INTRODUCTION

The Monoprice™ SB-300 Dolby Atmos® Soundbar features built-in Atmos height speakers for a true and powerful Dolby Atmos home theater experience. Two HDMI® inputs, an HDMI eARC output, coaxial and optical digital audio inputs, and a 3.5mm analog audio input allow you to connect your various audio and video devices, while the Bluetooth® 4.2 radio and USB input allow you to stream audio from your smartphone or PC. Enjoy total control from the comfort of your easy chair using the included IR remote control. The Monoprice SB-300 Dolby Atmos Soundbar delivers stellar looks and a complete home theater experience.

FEATURES

- Dolby Atmos® soundbar
- Two HDMI® inputs and an HDMI ARC output
- Bluetooth® 4.2 and USB streaming
- Coaxial and optical digital inputs
- 3.5mm analog audio input
- Four DSP sound modes
- Includes an IR remote control
- Includes a Premium High Speed HDMI® Cable and mounting hardware
- Automatic standby mode after 15 minutes of inactivity

CUSTOMER SERVICE

The Monoprice™ Customer Service department is dedicated to ensuring that your ordering, purchasing, and delivery experience is second to none. If you have any problem with your order, please give us an opportunity to make it right. You can contact a Monoprice Customer Service representative through the Live Chat link on our website www.monoprice.com or via email at support@monoprice.com. Check the website for support times and links.

PACKAGE CONTENTS

Please take an inventory of the package contents to ensure you have all the items listed below. If anything is missing or damaged, please contact Monoprice Customer Service for a replacement.

1x SB-300 Soundbar

1x Remote Control

2x AAA Batteries

1x AC Power Cord

1x Premium High Speed HDMI® Cable

1x 3.5mm Audio Cable

2x Wall Mount Brackets

4x Wall Mount Screws

4x Wall Mount Anchors

2x Mounting Screws

1x User's Manual

PRODUCT OVERVIEW

Overall

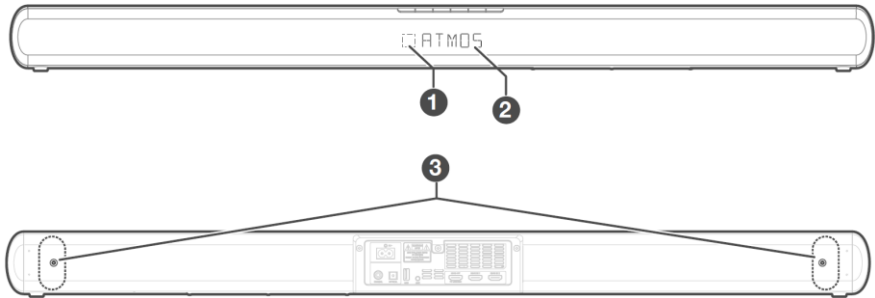

1. **IR RECEIVER:** The **IR RECEIVER** accepts signals from the included IR remote control. The remote control has a maximum operating range of up to 19.6 feet (6 meters) with angles up to $\pm 30^\circ$.
2. **DISPLAY:** The **DISPLAY** shows information about the status of the system, including the selected input. When audio playback begins, the display shows **DOLBY ATMOS**, **DOLBY DIGITAL**, **PCM**, or **NONSUPPORT FORMAT**, depending on the audio format.
3. **WALL MOUNT MOUNTING POINTS:** The soundbar mounting screws are installed to these two locations.

Top Panel

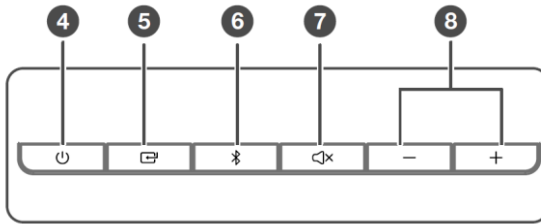

4. **⏻**: Press the **⏻** button to turn the system on or to put it into standby mode.
5. **□**: Press the **□** button to cycle through the inputs. The cycle order is **AUX, BT, OPT/COA, HDMI® 1/2, HDMI eARC, USB**.
6. **📶**: Press the **📶** button to select Bluetooth® mode.
7. **🔇**: Press the **🔇** button to turn audio mute on or off.
8. **-/+**: Press the **-** button to decrease the volume level and the **+** button to increase the volume level.



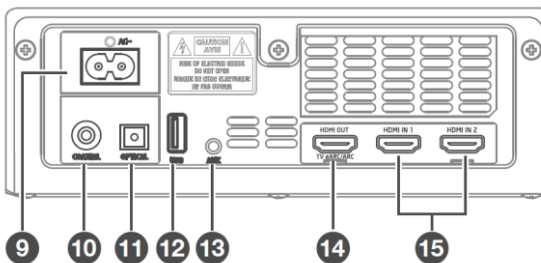





Rear Panel



9. **AC~**: AC power socket for connecting the included AC power cord.
10. **COAXIAL**: Digital coaxial audio input for connecting the coaxial output on your TV. Note that you can use either the **OPTICAL** or **COAXIAL** input, but not both.

11. **OPTICAL:** Digital optical audio input for connecting the optical output on your TV. Note that you can use either the **OPTICAL** or **COAXIAL** input, but not both.
12. **USB:** USB port for connecting a USB flash drive with mp3 files for audio playback. You can use flash drives up to 32GB capacity, formatted with the FAT16 or FAT32 file system. The files can be in subdirectories.
13. **AUX:** 3.5mm stereo audio input for connecting an external audio device, such as a smartphone or mp3 player or for connecting the analog audio outputs on your TV.
14. **HDMI OUT:** HDMI® port for connecting a TV. The port supports the eARC/ARC HDMI feature, which allows the soundbar to play audio that originates on the connected TV.
15. **HDMI IN:** Two HDMI ports for connecting HDMI source devices, such as a DVD player, Blu-ray Disc™ player, or gaming console. Note that only one HDMI input is usable at a time.

Remote Control

1. : Press the  button to turn the system on or to put it into standby mode.
2. : These rocker buttons (**AUX / BT**, **USB / OPT/COA**, and **HDMI 1/2 / HDMI® eARC**) are for selecting one of the input sources.
3. / / : Press the  button to skip back to the previous track when using the Bluetooth® (BT) or USB input. Press the  button to skip forward to the next track when

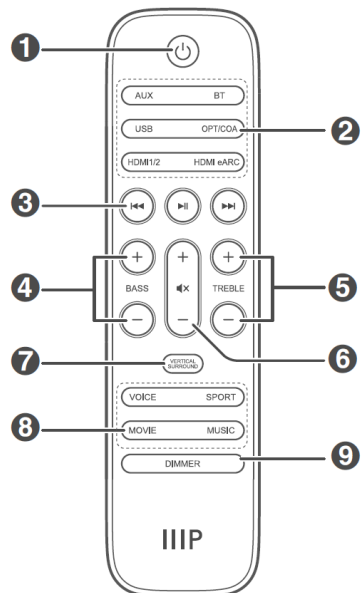

using the Bluetooth® (BT) or USB input. Momentarily press the ►|| button to pause or resume playback when using the Bluetooth (BT) or USB input. Press and hold the ►|| button for about 1 second to enter Bluetooth® pairing mode or to disconnect an existing paired Bluetooth device.

4. **BASS:** Press the + button to increase the bass response or press — the button decrease the bass response.
5. **TREBLE:** Press the + button to increase the treble response or press — the button decrease the treble response.
6. **+/-/🔇:** Press the + button to increase the volume level of the system or press the — button to decrease the volume level of the system. Press the 🔇 icon in the center of the button to toggle audio mute on or off. If audio is muted, increasing or decreasing the volume level toggles mute off.
7. **VERTICAL SURROUND:** Turns the Atmos® height speakers on or off.
8. **EQ:** These rocker buttons select one of the four DSP sound modes.
9. **DIMMER:** Adjusts the display brightness.

INSTALLATION

Safety Warning

Mounting the soundbar to the wall should be performed by qualified personnel only. Incorrect installation can result in severe personal injury or property damage. Care must be taken to avoid damage to any electrical wiring or plumbing inside the walls. It is the installer's responsibility to ensure that the wall can safely support the weight of the soundbar and wall mount brackets. Use a stud finder as necessary to find the studs on a wood stud drywall wall. Additional tools (not included) are required to install this speaker system.

Positioning

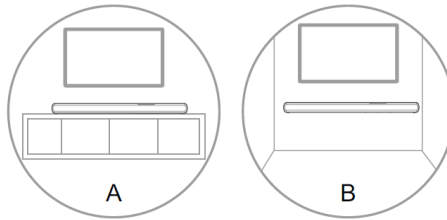

- A. If your TV is placed on a table, you can simply place the soundbar on the table in front of the TV's stand. The feet on the soundbar will protect the surface of your table.
- B. If your TV is mounted to a wall, you can mount the soundbar to the wall directly beneath the TV using the included wall mount brackets and mounting hardware.

Wall Mounting

Perform the following steps to mount the soundbar to the wall. Use common sense at all times.



1. Using a pencil, a carpenter's level, and a tape measure, mark two positions on the wall exactly **892mm** apart. Use the level to ensure that these marks are at the same height on the wall. These marks will be at the center of each wall mount bracket.

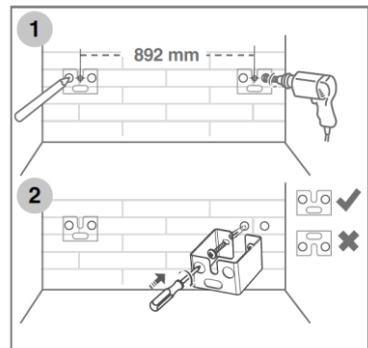

- For each mark, place one of the wall mount brackets against the wall, with the mark in the center of the notch. Use the level to ensure the bracket is level, then mark each hole in the bracket, which is where the two screws will be used to secure the bracket to the wall.
- Use a $\varnothing 5.5 \sim 6.0$ mm drill bit to drill a hole at each of the four marked screw hole locations.
- If using wall anchors, insert an anchor into each hole. If they do not insert fully by hand, lightly tap each anchor with a small hammer to drive them completely into the wall.
- Position each bracket over the holes, then use a #2 Phillips screwdriver and the wall mount bracket screws to secure each bracket to the wall. Take care not to overtighten the screws. Ensure that the opening of the notch is at the top of the bracket.
- Remove the two screws at the wall mount mounting locations on the rear of the subwoofer. Store them in a safe place in case you need to use them in the future.
- Install the mounting screws into the screw holes at the wall mount mounting locations.
- Position the soundbar so the mounting screws are positioned over the notches in the brackets, then slide it down into place.

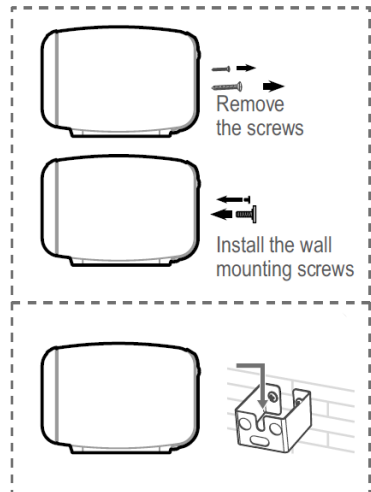

Remote Control

Perform the following steps to prepare the remote control for use.

1. Press and slide back the battery compartment cover on the remote control.
2. Insert two AAA batteries (included). Take care to match the polarity of the batteries with the markings inside the battery compartment.
3. Slide the battery compartment cover back into place.

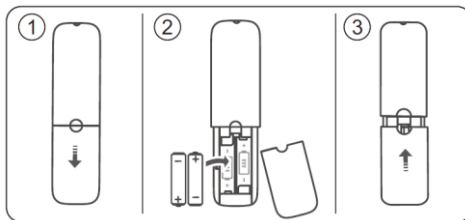

Notes:

- Remove the batteries from the controller if it will go unused for a lengthy period of time.
- You can use either rechargeable or non-rechargeable batteries.
- Do not mix new and old batteries or batteries of different types.
- Do not mix alkaline, standard, or rechargeable batteries with this product.

SOUNDBAR ENHANCED FEATURES

Dolby Atmos

One of the primary features of this soundbar is support for Dolby Atmos®. Dolby Atmos is an audio encoding method that delivers an immersive listening experience. It does this by using height speakers to create sound in three dimensional space. However, rather than requiring speakers physically mounted

in the ceiling or high on the walls, it uses upward firing drivers that bounce sound off the ceiling to create the three dimensional audio experience. Please visit <https://www.dolby.com/technologies/dolby-atmos> for more details.

The following elements are required for Dolby Atmos® support:

- Full Atmos support is only available when using one of the HDMI® inputs.
- You must use an HDMI cable that complies with the HDMI version 2.0 specification, such as the included Premium High Speed HDMI Cable.
- The HDMI source devices should have **No Encoding** selected for the audio bitstream.
- If using the eARC/ARC audio input, the TV must support Dolby Atmos.

eARC/ARC

This soundbar supports the HDMI® Audio Return Channel (ARC) and Enhanced Audio Return Channel (eARC) features, which allow it to receive and playback audio that originates on the connected TV. This is useful for when you watch broadcast TV or when using an app on a smart TV. When properly configured, you can use your TV's remote control to adjust the volume level and mute status of the soundbar.

The following elements are required to use the eARC/ARC feature:

- Your TV must support both the HDMI CEC (Consumer Electronics Control) and eARC or ARC features.
- You must enable CEC and eARC/ARC on your TV.
- The HDMI cable between the TV and the soundbar must comply with the HDMI version 1.4 specification or later.
- Your TV's digital sound output S/PDIF mode must be set to **PCM**.
- To use eARC/ARC, select the HDMI eARC input on the soundbar.

CONNECTIONS

HDMI OUT

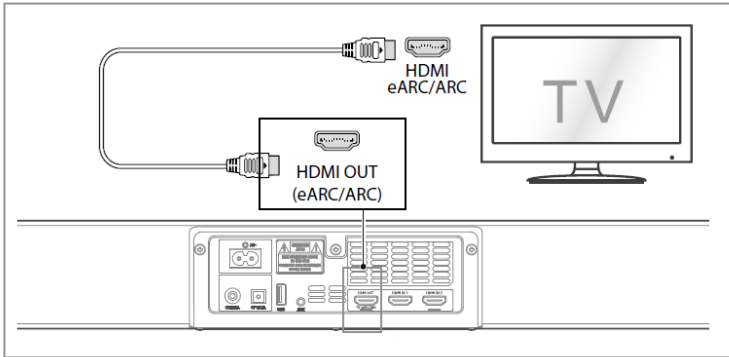

Use the included Premium High Speed HDMI® Cable to connect your TV to the soundbar. Plug one end of the cable into an HDMI input on your TV, then plug the other end into the **HDMI OUT TV eARC/ARC** port on the soundbar.

Notes:

- Some 4K HDR TVs require the HDMI input or picture settings to be set for HDR content reception. Please refer to your TV's user's manual for setup details.
- To use the eARC/ARC feature, you must connect to the HDMI input on your TV that supports eARC/ARC. Please refer to your TV's user's manual.
- If you want to use Dolby Atmos® with the eARC/ARC feature, your TV must support Dolby Atmos and you must use a Premium High Speed HDMI Cable, such as the one included with the soundbar.

HDMI IN 1/HDMI IN 2

Use Premium High Speed HDMI® Cables, such as the one included in the package, to connect your video source devices to the soundbar. Plug one end of the cable into the **HDMI IN 1** or **HDMI IN 2** port on the soundbar, then plug the other end into the HDMI output on your video source device.

Notes:

- Only one of the two HDMI inputs can be used at a time.
- If you will not be using Dolby Atmos® encoded content from either video source device, you can connect using a High Speed HDMI® Cable instead of a Premium High Speed HDMI Cable.

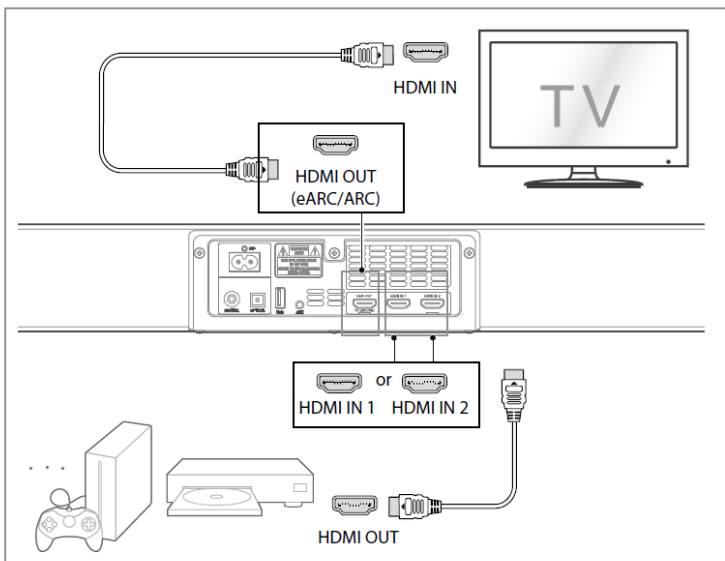

OPTICAL

Use a digital optical S/PDIF cable (not included) to connect your TV or other audio source device to the soundbar. First, remove the protective plug from the **OPTICAL** connector on the soundbar. Put it in a safe place for later use. Plug one end of an optical cable into the **OPTICAL** connector on the soundbar, then plug the other end into the optical output on your TV or other audio source device.

Notes:

- You can use either the **OPTICAL** input or the **COAXIAL** input, but not both at the same time.
- The **OPTICAL** input does not fully support Dolby Atmos®. For Dolby Atmos playback, use one of the HDMI® inputs.
- The soundbar is not capable of decoding all digital audio formats. If an unsupported format is detected, the audio will be muted. Ensure that the audio format of the input source device is set to **Dolby Digital™** or **PCM**.

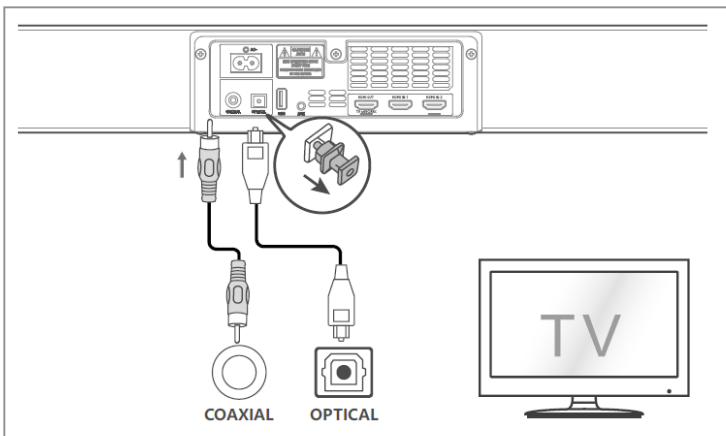

COAXIAL

Use a digital coaxial cable (not included) to connect your TV or other audio source device to the soundbar. Plug one end of a digital coaxial cable into the **COAXIAL** connector on the soundbar, then plug the other end into the coaxial output on your TV or other audio source device.

Notes:

- You can use either the **OPTICAL** input or the **COAXIAL** input, but not both at the same time.
- The **COAXIAL** input does not fully support Dolby Atmos®. For Dolby Atmos playback, use one of the HDMI® inputs.
- The soundbar is not capable of decoding all digital audio formats. If an unsupported format is detected, the audio will be muted. Ensure that the audio format of the input source device is set to **Dolby Digital™** or **PCM**.

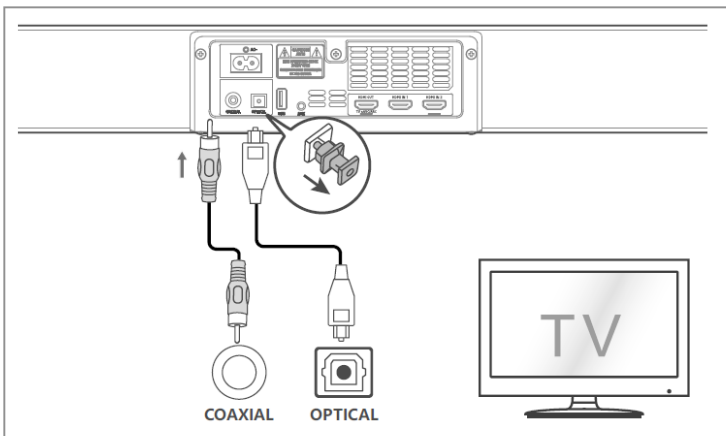

AUX

The **AUX** input is used to connect an analog audio source, such as your TV or the headphone output of your smartphone, to the soundbar.

To connect the headphone output of a device, plug one end of the included 3.5mm audio cable into the **AUX** input on the soundbar, then plug the other end into the headphone output of your source device.

To connect the stereo RCA outputs of a device to the soundbar, plug the 3.5mm end of a 3.5mm to RCA stereo audio cable (not included) into the **AUX** input on the soundbar, then plug the RCA end into the left and right RCA outputs of your source device.

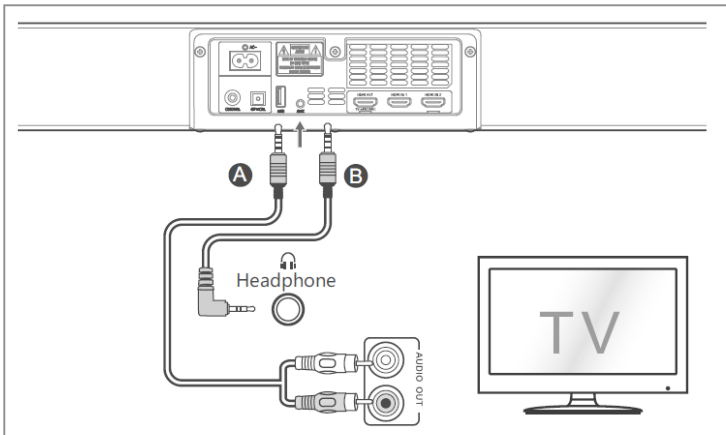

Power

Perform the following steps to connect the soundbar to AC power.

1. Ensure that all other connections have been made before connecting power.
2. Ensure that your AC power source provides the 100 ~ 240 VAC, 50/60 Hz mains power required by the soundbar.

3. Plug one end of the included AC power cord into the AC~ jack on the rear panel, then plug the other end into a nearby AC power socket.

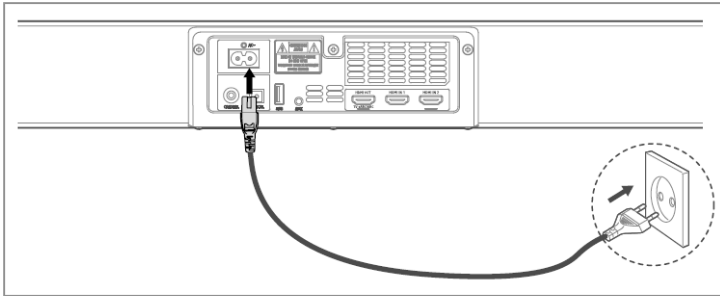

POWER SAVING

- After about 15 minutes of no detected audio or video signal, the soundbar will automatically enter standby mode to save power.
- If the soundbar is in standby mode, any detected audio or video signal will cause the soundbar to turn on.

BLUETOOTH OPERATION

The soundbar features a Bluetooth® radio, which allows you to wirelessly stream audio from a connected mobile device. Note that the connected device must support the Advanced Audio Distribution Profile (A2DP) to stream audio. If the connected device supports the Audio Video Remote Control Profile (AVRCP), you can use the soundbar's remote control to control playback.

Perform the following steps to pair your device with the soundbar:

1. With the soundbar powered on, press the  button on the soundbar top panel or the **BT** button on the remote control to select Bluetooth® mode. If not already paired with a device, the display will show **NO BT**, indicating that the soundbar is not paired with any nearby device.

2. Open the Bluetooth settings on your mobile device and scan for nearby Bluetooth devices.
3. Locate the **SB-300** entry. If you cannot find the **SB-300** entry, press and hold the **▶||** or **BT** button on the remote control for about 3 seconds, to reinitiate Bluetooth pairing. The soundbar will say **Pairing** and the display will show **PAIR**.
4. Select the **SB-300** entry from the list. If prompted for a passcode, enter **0000** (four zeros). Once the connection is made, the soundbar will say **Paired** and the display will show **BT**.
5. If your mobile device supports the AVRCP profile, press the **▶||** button on the remote control to start or pause playback. Use the **◀◀** and **▶▶** buttons on the remote control to skip tracks. If your device does not support AVRCP, you will need to control playback directly on your device.

Notes:

- If no Bluetooth device pairs with the soundbar within 2 minutes, Bluetooth pairing mode will cancel and the soundbar will return to its previous connection.
- The effective Bluetooth range is about 19 feet (8 meters) in clear air. Any obstructions between the soundbar and the mobile device can reduce that range.
- If a connected device is moved out of range, it will automatically disconnect. To reconnect, simply move the device back to within range of the soundbar.
- If your device fails to reconnect, perform the Bluetooth® pairing process again.

To disconnect your device from the soundbar, perform one of the following:

- Switch to a different mode on the soundbar.

- Disable Bluetooth® or manually disconnect the soundbar in your device's Bluetooth settings. The soundbar will say **Disconnected**.
- Press and hold the **▶||** or BT button on the remote control for about 3 seconds.

USB OPERATION

This soundbar features a USB port with the ability to playback audio from mp3 files stored on a USB flash drive. The maximum supported drive capacity is 32GB and the drive must be formatted with either the FAT16 or FAT32 file system. The files can be stored in subdirectories and/or the root directory.

1. Plug your flash drive into the **USB** port on the soundbar rear panel.
2. With the soundbar powered on, repeatedly press the  button on the soundbar top panel or the **USB** button on the remote control to select **USB** mode. The display on the front panel will show **USB**.
3. Press the **▶||** button on the remote control to start or pause playback. Use the **◀◀** and **▶▶** buttons on the remote control to skip tracks.

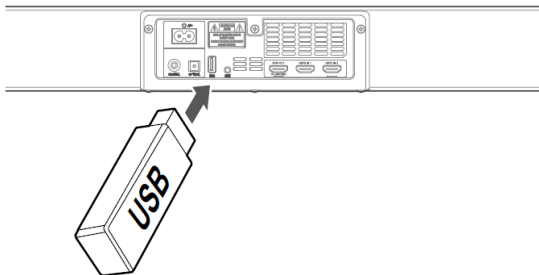

TROUBLESHOOTING

This section contains potential solutions to commonly issues.





There is no power to the soundbar.

- Ensure that the soundbar is plugged into a nearby AC power outlet.
- Ensure that the outlet is live by plugging another device into it, such as a lamp.

The remote control doesn't work.

- Reduce the distance between the remote control and the soundbar.
- Reduce the angle and aim directly at the IR RECEIVER on the front of the soundbar.
- Replace the batteries in the remote control.

There is no sound.

- Press the  button or the volume  button to ensure that the system is not muted.
- Press the  button the soundbar top panel or remote control to put the system into standby mode, then press it again to turn the system back on.
- Unplug the soundbar and subwoofer from the wall outlet, wait 30 seconds, then plug them back in again. Press the  button the soundbar top panel or remote control to turn the system back on.
- The system cannot decode all digital audio formats and will mute if an unsupported format is detected. Ensure that the audio setting of the **HDMI®**, **OPTICAL**, or **COAXIAL** source device is set to PCM or Dolby Digital™.

- Ensure that the subwoofer is within range of the soundbar. Move it closer to the soundbar.
- The pairing between the soundbar and subwoofer may have been lost. Perform the manual pairing procedure to pair the soundbar and subwoofer.

The TV has display problems when viewing HDR content from an HDMI source.

- Some 4K HDR TVs require the HDMI input or picture settings be configured for HDR content. Refer to your TV's user's manual for instructions on configuring this setting.

I cannot find the SB-300 entry in my Bluetooth® connections list.

- Ensure that Bluetooth is enabled on your device.
- Perform a scan for active Bluetooth devices to connect to.
- Press and hold the **▶||** or **BT** button to put the soundbar into Bluetooth pairing mode, then scan for active Bluetooth devices.

The system entered standby mode without pressing the button the soundbar top panel or remote control.

- This is normal operation. This system supports the ERPII requirement for power saving and automatically goes into standby mode after 15 minutes of no detected input signal. If you were playing audio, increase the output volume of your source device.

TECHNICAL SUPPORT

Monoprice is pleased to provide free, live, online technical support to assist you with any questions you may have about installation, setup, troubleshooting, or product recommendations. If you ever need assistance with your new product, please come online to talk to one of our friendly and knowledgeable Tech Support Associates. Technical support is available through the online chat button on our website www.monoprice.com or through email by sending a message to tech@monoprice.com. Check the website for support times and links.

To download the latest drivers, firmware, manuals, etc., go to www.monoprice.com and type the P/N into the search bar. If available, support files are linked at the bottom of the product page.

SPECIFICATIONS

P/N	42033
Video Inputs	2x HDMI®
Video Output	HDMI with eARC
Audio Inputs	Digital Coaxial, Digital Optical, 3.5mm Analog
Audio Input Sensitivity	500mV
Nominal Impedance	2x 4Ω
Frequency Response	40Hz ~ 20kHz
Bluetooth® Version	4.2
Amplifier Power	2x 50 watts
Supported Bluetooth Profiles	A2DP, AVRCP
Bluetooth Frequency Range	2400 ~ 2483.5 MHz

Bluetooth Maximum Transmission Power	≤ 5dBm
USB Version	2.0
Supported USB Formatting	FAT32, FAT16
Maximum Supported USB Capacity	32GB
Supported USB File Format	mp3
Remote Control Range	up to 19.6 feet (6 meters)
Remote Control Operating Angle	0 ~ 30°
Remote Control Power Source	2x AAA batteries (included)
Input Power	100 ~ 240 VAC, 50/60 Hz
Maximum Power Consumption	30 watts
Standby Power Consumption	≤ 0.5 watts
Dimensions	39.4" x 2.9" x 4.2" (1000 x 74 x 106 mm)
Weight	6.0 lbs. (2.7 kg)

REGULATORY COMPLIANCE

Notice for FCC



This device complies with Part 15 of the FCC rules. Operation is subject to the following two conditions: (1) this device may not cause harmful interference, and (2) this device must accept any interference received, including interference that may cause undesired operation.

Modifying the equipment without Monoprice's authorization may result in the equipment no longer complying with FCC requirements for Class B digital devices. In that event, your right to use the equipment may be limited by FCC regulations, and you may be required to correct any interference to radio or television communications at your own expense.

This equipment has been tested and found to comply with the limits for a Class B digital device, pursuant to Part 15 of the FCC Rules. These limits are designed to provide reasonable protection against harmful interference in a residential installation. This equipment generates, uses and can radiate radio frequency energy and, if not installed and used in accordance with the instructions, may cause harmful interference to radio communications. However, there is no guarantee that interference will not occur in a particular installation. If this equipment does cause harmful interference to radio or television reception, which can be determined by turning the equipment off and on, the user is encouraged to try to correct the interference by one or more of the following measures:

- Reorient or relocate the receiving antenna.
- Increase the separation between the equipment and receiver.
- Connect the equipment into an outlet on a circuit different from that to which the receiver is connected.
- Consult the dealer or an experienced radio/TV technician for help.

RF Exposure Statement for FCC

Caution

This equipment complies with radiation exposure limits set forth for an uncontrolled environment. End users must follow the specific operating instructions for satisfying RF exposure compliance. This transmitter must be at least 20 cm from the user and must not be collocated or operated in conjunction with any other antenna or transmitter.

Notice for Industry Canada

This Class B digital apparatus complies with Canadian ICES-003.

Cet appareil numérique de la classe B est conforme à la norme NMB-003 du Canada.

RF Exposure Statement for Industry Canada

Caution

This equipment complies with radiation exposure limits set forth for an uncontrolled environment. End users must follow the specific operating instructions for satisfying RF exposure compliance. This transmitter must be at least 20 cm from the user and must not be collocated or operated in conjunction with any other antenna or transmitter.

Monoprice™ and all Monoprice logos are trademarks of Monoprice Inc.

Dolby®, Dolby Atmos®, Dolby Digital™, the Dolby Atmos logo, and the double-D symbol are trademarks of Dolby Laboratories.

HDMI®, the HDMI Logo, and High-Definition Multimedia Interface are trademarks or registered trademarks of HDMI Licensing LLC in the United States and other countries.

The Bluetooth® word mark and logos are registered trademarks of Bluetooth SIG, Inc.

Blu-ray Disc™, Blu-ray™, and the logos are trademarks of the Blu-ray Disc Association.