

# Monoprice Adjustable Tilt/Swivel Flat Panel Wall Mount

Model MLB-WA8 (PID# 4562)

VESA Compliant up to 700x500  
Max Weight: 110lbs

## Installation Instructions

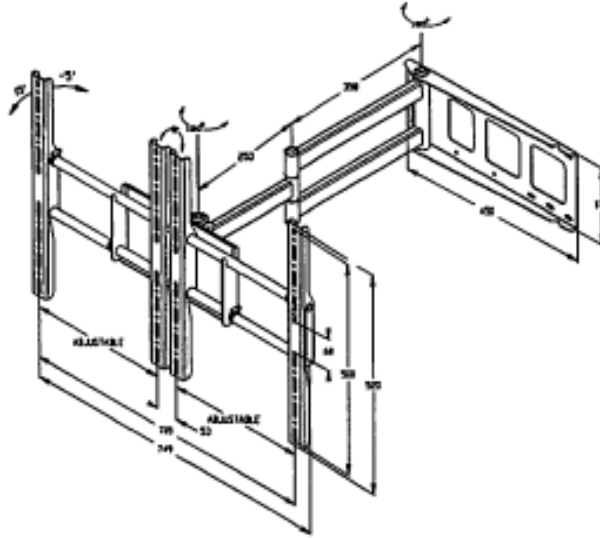

### UNPACKING INSTRUCTIONS

- Carefully open the carton, remove the contents and lay them out on cardboard or other protective surface to avoid damage.
- Check the contents against the supplied parts list on the next page to assure that all components were received undamaged. Do not use any damaged or defective parts.

### IMPORTANT SAFETY INFORMATION

Install and use this device with care. Please read this entire manual before attempting installation and carefully follow all instructions contained herein. Use proper safety equipment during installation.

Please call a qualified installation contractor for help if you:

- Don't understand the instructions in this manual or have any doubts about the safety of the installation.
- You are uncertain about the nature of your wall.

Do not use this product for any purpose or in any configuration not explicitly specified in these instructions. Monoprice hereby disclaims any and all liability for injury or damage arising from incorrect assembly, incorrect mounting or any incorrect use of this product.



**WARNING**

### CAUTION!

**This TV mount must be securely attached to the vertical wall. If the mount is not properly installed it may fall, resulting in possible injury and/or damage.**

#### Tools Required

■ 3/16" Drill Bit

■ Phillips Screwdriver

■ 1/2" Masonry Bit

■ Stud Finder

■ Wrench or Socket Set

■ Carpenter's Level

**Note:** The mounting components and hardware supplied in this package are not designed for installation to wall with steel studs or to cinder block walls. If the hardware you need for your installation is not included, please consult your local hardware store for proper mounting hardware for this application.

## Supplied Parts List

ITEM	①	②	③	④	⑤	⑥
PART						
QTY	1	2	2	2	4	4

ITEM	⑦	⑧
PART		
QTY	7	7

ITEM	⑨	⑩	⑪	⑫	⑬	⑭	⑮	⑯	⑰	⑱	⑲	
PART												
QTY	4	4	4	4	4	4	4	4	4	8	8	1

## Step 1

## Mounting the Wall Plate to the Wall

### Brick, Solid Concrete and Concrete Block Mounting:

Use the Wall Plate (part 1) as a template to mark 7 hole locations on the wall. Three in the top row of slots, three more in the bottom row and the last between the top and bottom screws on the left hand side. Make sure these holes are level. Pre-Drill these holes with a 1/2" masonry bit to at least 2.5" in depth. Insert a Concrete Anchor (part 8) into each of these holes. Make sure the anchor is seated completely flush with the concrete surface even if there is a layer of drywall or the other material in front. Attach the Wall Plate to the wall using 7 Lag Bolts (part 7), as shown in the diagram.

### Wood Stud mounting:

The Wall Plate (part a) must be mounted to two wood studs. Use a stud finder to locate two adjacent studs. It is a good idea to verify where the studs are located with an awl or thin nail. Pre-drill a 2.5" deep hole at the desired height in each stud using a 3/16" drill bit. Make sure these holes are in the center of the studs and level with each other. Use the Wall Plate as a template to mark the location of the other holes in each stud. Drill pilot holes at each of the marked locations. Attach the Wall Plate to the wall using the 5 Lag Bolts (part 7).

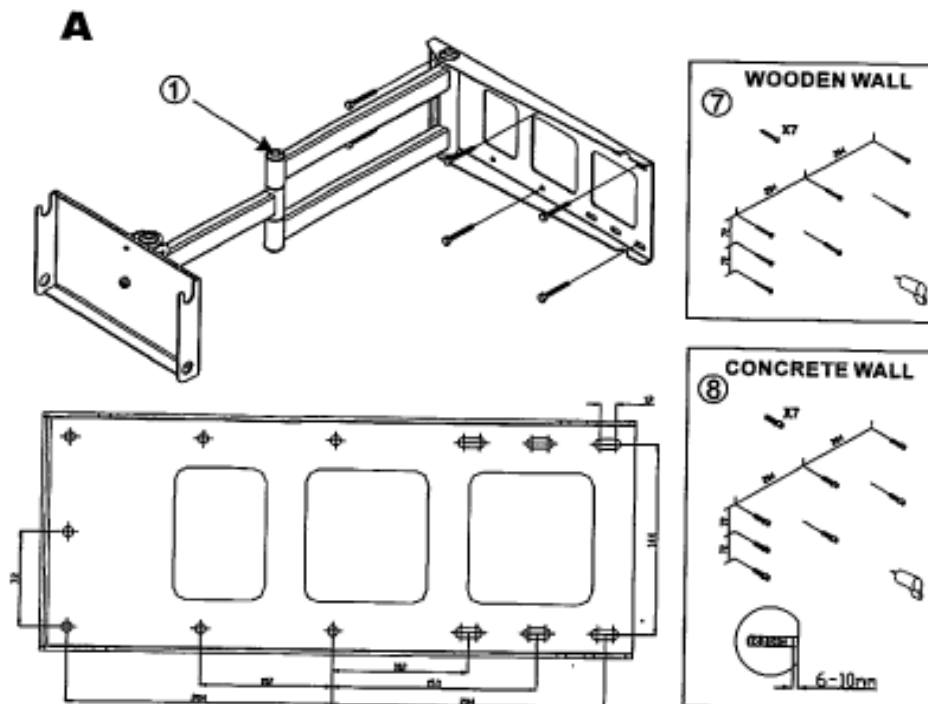

## Step 2

## Mounting the Monitor Bracket Frame to a TV

The arrangement of the TV mounting rails (part 2) will depend on the horizontal distance between the mounting holes on the back of your television. Before attaching the vertical TV mounting rails to the television, please determine which setup is appropriate for your television in order to determine the proper placement of the retention clamps (part 5).

### Case A.

If the mounting holes on your television are 54 to 235mm. TV mounting rails will go inside of the extension arm plate and retention clamps go on outside of the rails.

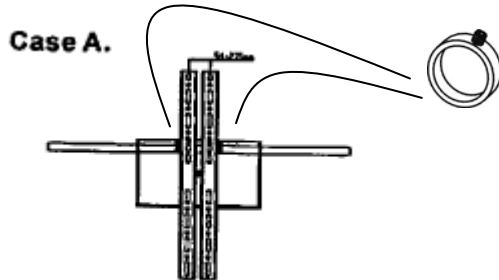

### Case B.

If the mounting holes on your television are 235-257mm. TV mounting rails will go inside the extension arm plate and retention clamps go on the inside of the rails.

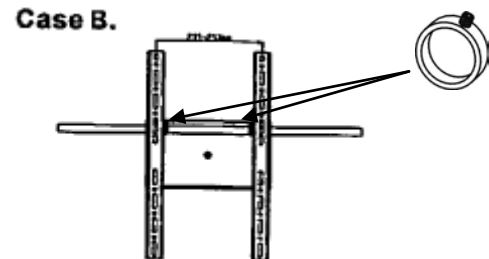

### Case C.

If the mounting holes on your television are 346-683mm. TV mounting rails will go outside the extension arm plate and the retention clamps go outside the rails.

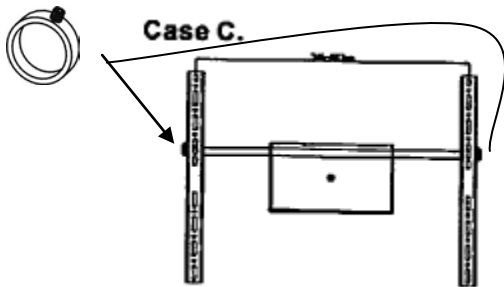

### Case D.

If the mounting holes on your television are 683-705-257mm. TV mounting rails will go outside the extension arm plate and the retention clamps go on the inside of the rails.

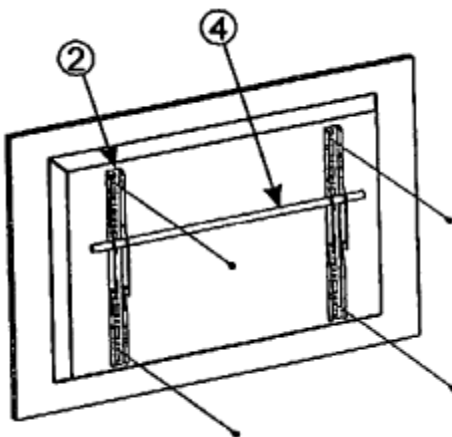
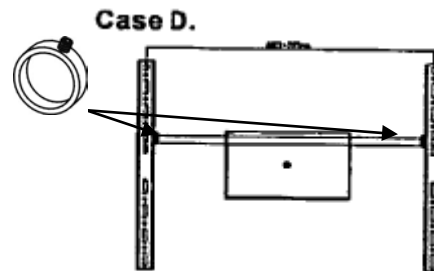

Make sure one of the machine bolt sizes fits the mounting holes on your television.

Once you have selected the correct size bolt, attach the rails to the television with the retention clamps slid onto the horizontal frame rod (part 4) at the appropriate location. Use four machine screws to attach the rails to the television, 2 per rail.

9 + 16 + 17		M4x30
10 + 17		M5x16
11 + 17		M5x30
12		M6x20
13		M6x30
14		M8x16
15		M8x40

### Step 3

### Attaching the TV to the Mounting Arm

Slide the bottom horizontal frame rod (part 4) through the holes on the bottom of the extension arm mounting plate. Slide on the retention clamps (part 5) on their appropriate positions as illustrated in the diagram based on your selection for the appropriate case scenario in step 2.

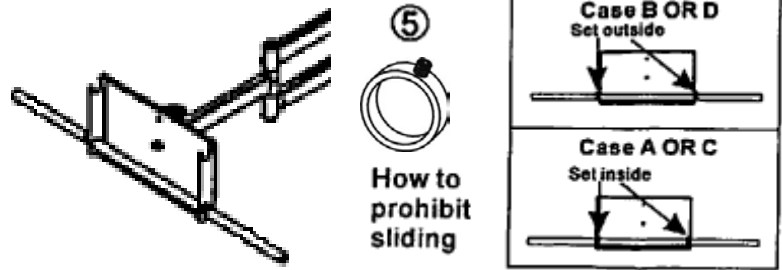

**Warning: Some TVs may require two people to lift! Monoprice is not responsible for personal injury or product damage.**

With assistance, lift your television up onto the mounting arm. The bottom of the TV mounting rails that are already attached to the TV will hook onto the bottom rod already on the extension arm plate and the top frame rod already on the TV will hook onto the top of the mounting plate as shown in the diagram. Secure the installation by attaching the mounting frame end plates (part 3) to the ends of the frame rods with the M8 machine screw (part 6). Center your TV and tighten the retention clamps to hold the frame in position and keep the frame from sliding.

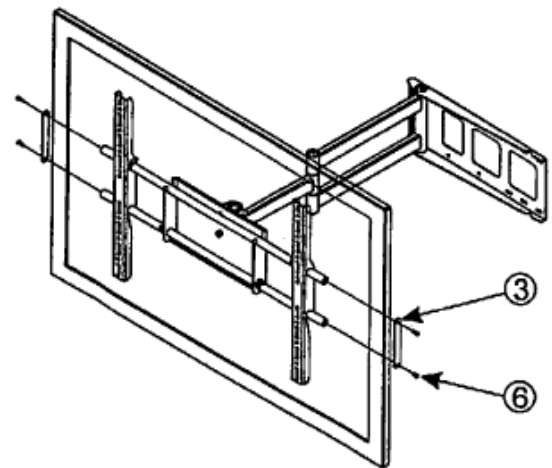

### Step 4

### Adjusting the TV

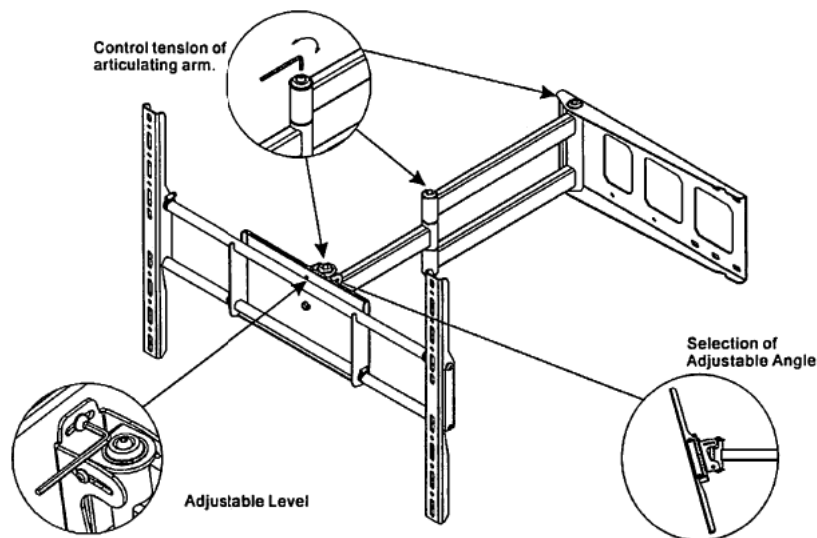

**Thanks for Choosing a Monoprice Wall Mount. Enjoy!**