

STAGE RIGHT

Stage Right Mini PAR 15-Watt LED Light (RGBW)

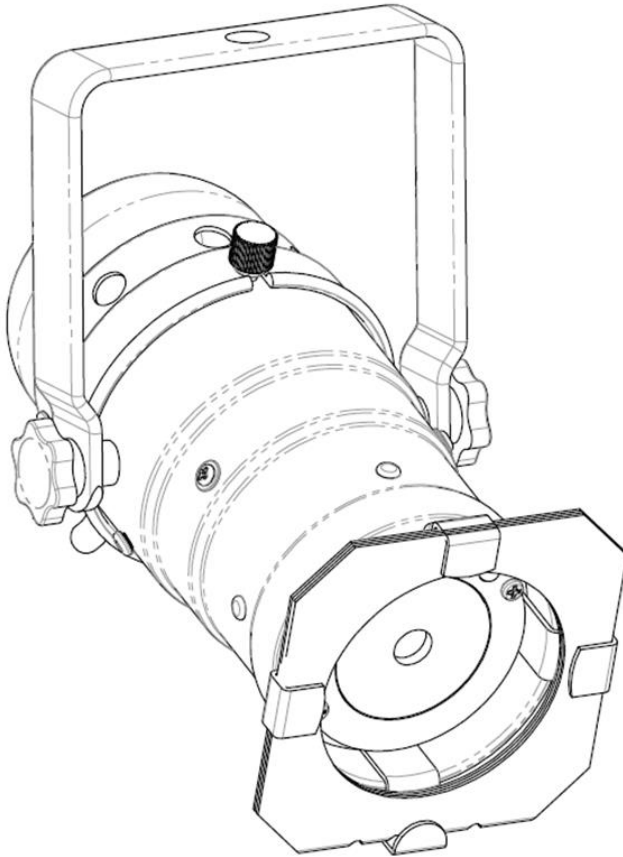

P/N 612732

User's Manual

SAFETY WARNINGS AND GUIDELINES

Please read this entire manual before using this device, paying extra attention to these safety warnings and guidelines. Please keep this manual in a safe place for future reference.

- This device is intended for indoor use only.
- Do not expose this device to water or moisture of any kind. Do not place drinks or other containers with moisture on or near the device. If moisture does get in or on the device, immediately unplug it from the power outlet and allow it to fully dry before reapplying power.
- When installing this device, ensure that the mount is sufficiently robust to support the weight of the unit and to prevent unwanted movement.
- Always secure the device to the mount using a safety wire or chain sufficiently robust to bear the weight of the device.
- Do not subject the product to extreme force, shock, or fluctuations in temperature or humidity.
- Do not touch the device, the power cord, or any other connected cables with wet hands.
- Do not expose this device to excessively high temperatures. Do not place it in, on, or near heat sources, such as a fireplace, stove, radiator, etc. Do not leave it in direct sunlight.
- This device ventilates excessive heat through the slots and openings in the case. Do not block or cover these openings. Ensure that the device is in an open area where it can get sufficient airflow to keep from overheating.
- Do not expose this device to excessively high temperatures. Do not place it in, on, or near heat sources, such as a fireplace, stove, radiator, etc. Do not leave it in direct sunlight.
- Do not operate this device when the ambient temperature exceeds +104°F (+40°C).
- Ensure that there is sufficient ventilation to allow the unit to cool. Do not block any ventilation vents or slots and ensure that there are no flammable materials or adjacent surfaces within 20 inches of this device.

- Prior to operation, check the unit and power cord for physical damage. Do not use if physical damage has occurred.
- Before plugging the unit into a power outlet, ensure that the outlet provides the same type and level of power required by the device.
- This device uses a grounded power cord and requires a ground connection for safe operation. Ensure that the power source has a proper ground connection. Do not modify the plug or use a "cheater" plug to bypass the ground connection.
- Unplug this device from the power source when not in use.
- Never unplug the unit by pulling on the power cord. Always grasp the connector head or adapter body.
- Take care to prevent damage to the power cord. Do not allow it to become crimped, pinched, walked on, or become tangled with other cords. Ensure that the power cord does not present a tripping hazard.
- Never connect this device to a dimmer pack.
- Clean using a soft, dry cloth only. Do not use chemical cleaners, solvents, or detergents. For stubborn deposits, moisten the cloth with warm water.
- This device has no user serviceable parts. Do not attempt to open, service, or modify this device.
- Avoid direct eye exposure to the light from this device. Do not look directly into the light source.

INTRODUCTION

Thank you for purchasing this Stage Right Mini PAR 15-Watt LED Light! This light features a single 15-watt RGBW 4-in-1 LED. It includes an IR remote control for easy operation. It has a greater than 1.5kHz refresh rate, ensuring flicker free operation for television broadcasts and video recording.

FEATURES

- 15-watt RGBW 4-in-1 LED
- Includes IR remote control
- Includes flash, strobe, fade, and smooth color changing programs
- Features a sound activated mode
- 1.5kHz refresh rate
- Flicker free for television broadcasts and video recording

CUSTOMER SERVICE

The Monoprice Customer Service department is dedicated to ensuring that your ordering, purchasing, and delivery experience is second to none. If you have any problem with your order, please give us an opportunity to make it right. You can contact a Monoprice Customer Service representative through the Live Chat link on our website

www.monoprice.com during normal business hours (Mon-Fri: 5am-7pm PT, Sat-Sun: 9am-6pm PT) or via email at **support@monoprice.com**

PACKAGE CONTENTS

Please take an inventory of the package contents to ensure you have all the items listed below. If anything is missing or damaged, please contact Monoprice Customer Service for a replacement.

1x 15-watt RGBW 4-in-1 LED stage light

1x IR remote control

1x Gel Frame

1x Diffusion Gel

1x User's manual

IR REMOTE CONTROL

The following table identifies the function for each button on the remote control. The two buttons in the upper left corner control brightness when a solid color is displayed. They control program speed when using one of the built-in programs.

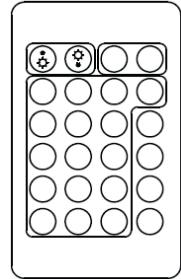

Dimming+ / Speed+	Dimming- / Speed-	Power Off	Power On
Red	Green	Blue	White
100%R+24%G	90%G+23%B	22%R+87%B	Flash
100%R+47%G	82%G+46%B	48%R+75%B	Strobe
100%R+71%G	72%G+69%B	67%R+62%B	Fade
100%R+100%G	Sound Control	100%R+100%B	Smooth

DIMENSIONS DIAGRAM

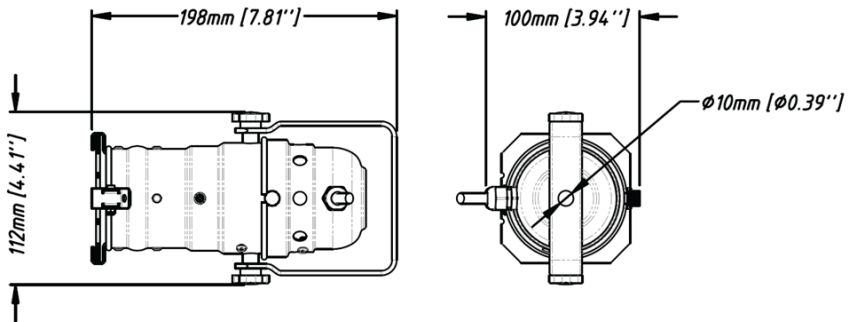

TECHNICAL SUPPORT

Monoprice is pleased to provide free, live, online technical support to assist you with any questions you may have about installation, setup, troubleshooting, or product recommendations. If you ever need assistance with your new product, please come online to talk to one of our friendly and knowledgeable Tech Support Associates. Technical support is available through the online chat button on our website www.monoprice.com during regular business hours, 7 days a week. You can also get assistance through email by sending a message to tech@monoprice.com

SPECIFICATIONS

Model	612732
Light Source	1x 15-watt RGBW 4-in-1 LED
LED Lifespan	50,000 ~ 100,000 hours
Control	IR remote control
Refresh Rate	1.5kHz, flicker free for television broadcasts and video recording
Beam Angle	30°
Protection Grade	IP20
Input Power	100 ~ 260 VAC, 50/60 Hz
Maximum Power Consumption	18 watts
Dimensions	4.4" x 3.9" x 7.8" (112 x 100 x 198 mm)
Weight	1.5 lbs. (0.7 kg)

REGULATORY COMPLIANCE

Notice for FCC



This device complies with Part 15 of the FCC rules. Operation is subject to the following two conditions: (1) this device may not cause harmful interference, and (2) this device must accept any interference received, including interference that may cause undesired operation.

Modifying the equipment without Monoprice's authorization may result in the equipment no longer complying with FCC requirements for Class B digital devices. In that event, your right to use the equipment may be limited by FCC regulations, and you may be required to correct any interference to radio or television communications at your own expense.

This equipment has been tested and found to comply with the limits for a Class B digital device, pursuant to Part 15 of the FCC Rules. These limits are designed to provide reasonable protection against harmful interference in a residential installation. This

equipment generates, uses and can radiate radio frequency energy and, if not installed and used in accordance with the instructions, may cause harmful interference to radio communications. However, there is no guarantee that interference will not occur in a particular installation. If this equipment does cause harmful interference to radio or television reception, which can be determined by turning the equipment off and on, the user is encouraged to try to correct the interference by one or more of the following measures:

- Reorient or relocate the receiving antenna.
- Increase the separation between the equipment and receiver.
- Connect the equipment into an outlet on a circuit different from that to which the receiver is connected.
- Consult the dealer or an experienced radio/TV technician for help.

Notice for Industry Canada

This Class B digital apparatus complies with Canadian ICES-003.

Cet appareil numérique de la classe B est conforme à la norme NMB-003 du Canada.