

# MONOPRICE

SoftStage™ 80-Watt COB LED Stage PAR (RGB)  
with 30° and 80° Lenses



P/N 612768

**User's Manual**

# CONTENTS

SAFETY WARNINGS AND GUIDELINES .....	3
FEATURES .....	5
CUSTOMER SERVICE.....	5
PACKAGE CONTENTS.....	5
DIMENSIONS DIAGRAM.....	6
SAMPLE WIRING DIAGRAM.....	6
DMX TERMINATION.....	7
CONTROL PANEL.....	7
CONTROLS AND MENU DISPLAY.....	8
MENU MAP.....	9
nodE FUNCTION.....	9
PRESETS.....	10
MASTER/SLAVE MODE.....	10
DMX CONTROL.....	11
3CH MODE .....	11
6CH MODE .....	11
7/8CH MODE.....	12
CHANGING THE LENS.....	14
TROUBLESHOOTING .....	15
TECHNICAL SUPPORT.....	15
SPECIFICATIONS.....	16
REGULATORY COMPLIANCE.....	17
Notice for FCC.....	17
Notice for Industry Canada.....	17

## SAFETY WARNINGS AND GUIDELINES

Please read this entire manual before using this device, paying extra attention to these safety warnings and guidelines. Please keep this manual in a safe place for future reference.

- This device is intended for indoor use only.
- Do not expose this device to water or moisture of any kind. Do not place drinks or other containers with moisture on or near the device. If moisture does get in or on the device, immediately unplug it from the power outlet and allow it to fully dry before reapplying power.
- When installing this device, ensure that the mount is sufficiently robust to support the weight of the unit and to prevent unwanted movement.
- Always secure the device to the mount using a safety wire or chain sufficiently robust to bear the weight of the device.
- Do not subject the product to extreme force, shock, or fluctuations in temperature or humidity.
- Do not touch the device, the power cord, or any other connected cables with wet hands.
- Do not expose this device to excessively high temperatures. Do not place it in, on, or near heat sources, such as a fireplace, stove, radiator, etc. Do not leave it in direct sunlight.
- This device ventilates excessive heat through the slots and openings in the case. Do not block or cover these openings. Ensure that the device is in an open area where it can get sufficient airflow to keep from overheating.
- Do not expose this device to excessively high temperatures. Do not place it in, on, or near heat sources, such as a fireplace, stove, radiator, etc. Do not leave it in direct sunlight.

- Do not operate this device when the ambient temperature exceeds +104°F (+40°C).
- Ensure that there is sufficient ventilation to allow the unit to cool. Do not block any ventilation vents or slots and ensure that there are no flammable materials or adjacent surfaces within 20 inches of this device.
- Prior to operation, check the unit and power cord for physical damage. Do not use if physical damage has occurred.
- Before plugging the unit into a power outlet, ensure that the outlet provides the same type and level of power required by the device.
- This device uses a grounded power cord and requires a ground connection for safe operation. Ensure that the power source has a proper ground connection. Do not modify the plug or use a "cheater" plug to bypass the ground connection.
- Unplug this device from the power source when not in use.
- Never unplug the unit by pulling on the power cord. Always grasp the connector head or adapter body.
- Take care to prevent damage to the power cord. Do not allow it to become crimped, pinched, walked on, or become tangled with other cords. Ensure that the power cord does not present a tripping hazard.
- Clean using a soft, dry cloth only. Do not use chemical cleaners, solvents, or detergents. For stubborn deposits, moisten the cloth with warm water.
- This device has no user serviceable parts. Do not attempt to open, service, or modify this device.
- Avoid direct eye exposure to the light from this device. Do not look directly into the light source.

## FEATURES

- One 80-watt RGB 3-in-1 COB LED with 30° and 80° lenses
- 3, 6, 7, and 8-channel DMX control modes
- 16 built-in presets/programs
- 32-bit smooth dimming technology
- Flicker-free for TV and camera shooting
- Variable electronic strobe, dimming, and color changing effects
- Stand-alone, Master/Slave, and DMX modes

## CUSTOMER SERVICE

The Monoprice Customer Service department is dedicated to ensuring that your ordering, purchasing, and delivery experience is second to none. If you have any problem with your order, please give us an opportunity to make it right. You can contact a Monoprice Customer Service representative through the Live Chat link on our website [www.monoprice.com](http://www.monoprice.com) during normal business hours (Mon-Fri: 5am-7pm PT, Sat-Sun: 9am-6pm PT) or via email at [support@monoprice.com](mailto:support@monoprice.com)

## PACKAGE CONTENTS

Please take an inventory of the package contents to ensure you have all the items listed below. If anything is missing or damaged, please contact Monoprice Customer Service for a replacement.

1x 80-Watt COB LED stage PAR

1x 80° lens

1x AC power cord (NAC3F to NEMA 5-15)

1x User's manual

# DIMENSIONS DIAGRAM

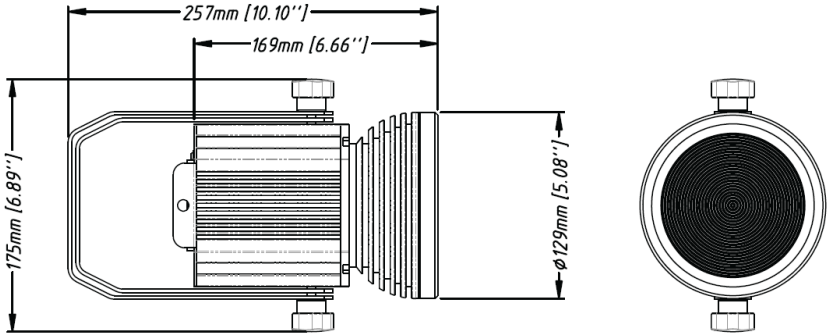

# SAMPLE WIRING DIAGRAM

Following is a sample wiring diagram for a multiple fixture installation. Note that the final fixture must have a DMX Terminator plugged into the **DMX Out** connector.

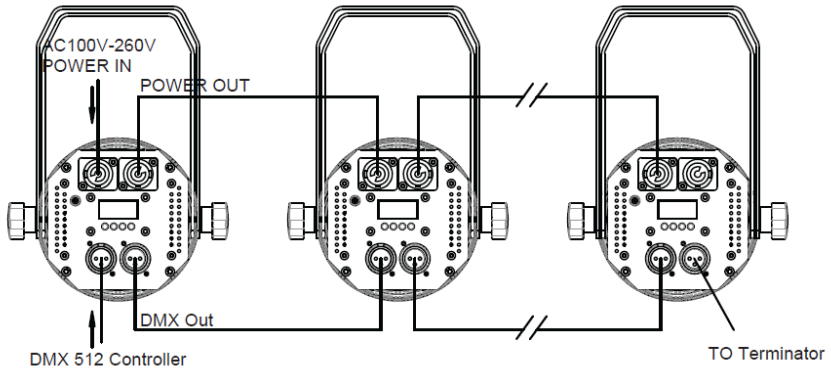

# DMX TERMINATION

As with all DMX devices, the last unit in any chain must have a DMX terminator connected to the **DMX Out** connector. If using just a single light, connect a DMX terminator to the **DMX Out** connector.



A DMX terminator is a DMX plug with a 120-ohm, 1/4-watt resistor soldered between pins 2 and 3.

# CONTROL PANEL

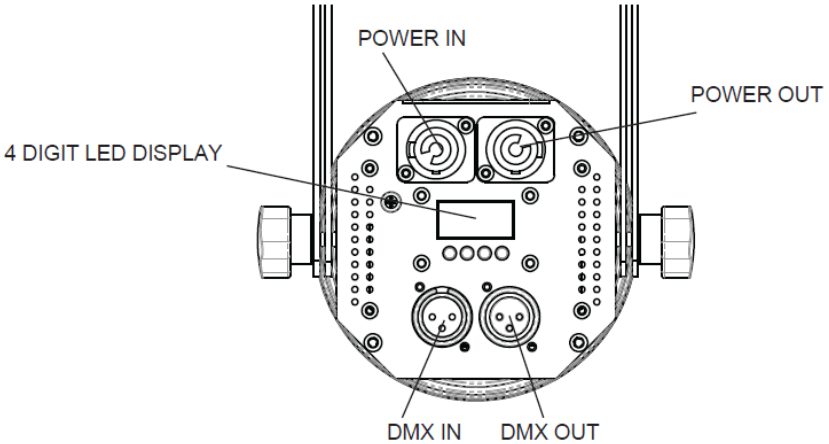

## CONTROLS AND MENU DISPLAY

The 4-digit LED display indicates the mode and the value for the selected function or mode. When the light is first plugged in, the display will show the last DMX channel number set (d001 by default).



- Press the **MENU** button to access the menu system.
- Press the **ENTER** button to edit the currently displayed mode.
- Press the **UP** button to increase the value of the selected function or mode. Press and hold the button to rapidly increase the displayed value. The list will cycle back to the beginning after the maximum value is reached.
- Press the **DOWN** button to decrease the value of the selected function or mode. Press and hold the button to rapidly decrease the displayed value. The list will cycle back to the end after the minimum value is reached.
- Once the desired value is displayed, press the **ENTER** button to set that value for the displayed function or mode and allow for selection of another function or mode.
- If you want to discard any changes made to the value of the selected function or mode, press the **MENU** button to cancel editing.



## MENU MAP

MODE	VALUES	DESCRIPTION
Addr	d001 - d512	DMX address
UErn	UE2.0	Displays the software version number
nodE	nod0 - nod4	Speed limiter (see the <b>nodE</b> section for details)
LEd	on/oFF	LED display on/auto off after 2 minutes of inactivity
SoJA	So.UA	Sound activation multicolor jump mode on/off
bL--	b000 - b255	Blue dimming
GL--	G000 - G255	Green dimming
rL--	r000 - r255	Red dimming
FLAS	FL00 - FL99	Strobe mode (fast-slow), 00=No FX
FAde	FA00 - FA99	Color fade (fast-slow)
ASC-	AC00 - AC99	Color jump change
Pr--	Pr00 - Pr15	Preset selection (see <b>Presets</b> section for details)
SP--	SP00 - SP99	Program speed (fast-slow)
SLAU	SL.AU	Slave mode
CHnd	3, 6, 7, 8CH	DMX channel selection

## nodE FUNCTION

The nodE function serves as a speed limiter for manual dims and fades. When set to nod0, any manual dims or fades will occur in real time, meaning that the light will dim or fade as fast as you move the slider. The other nodE values (1-4) are progressively slower than real time. It is recommended to use the nod1 value if using a low-res DMX controller.

## PRESETS

Following is a list of the functions for the 16 built-in Presets:

#	Function	#	Function
00	Red	08	Green Strobe
01	Green	09	Blue Strobe
02	Blue	10	Amber Strobe
03	Amber	11	Cyan Strobe
04	Cyan	12	Violet Strobe
05	Violet	13	White Strobe
06	White	14	RGB Color Jump
07	Red Strobe	15	Multicolor Jump

## MASTER/SLAVE MODE

Whenever the light is set to a mode other than a DMX address of Slave mode (**SLAU**), the fixture is in Master mode. For example, when set to Sound Activation mode (**SoUA**), it is in Master mode. You can daisy-chain additional fixtures to the Master fixture using 3-pin DMX cables. All other connected fixtures must be set to Slave mode (**SLUA**) and will perform the same functions as the Master fixture. Note that the final fixture in the daisy-chain must have a DMX terminator connected to the **DMX Out** connector. Note that you cannot use a DMX controller when connecting multiple lights in Master/Slave mode.

## DMX CONTROL

When the light is set to a DMX address it will respond to signals from a DMX controller. The number and complexity of the signals it can respond to correspond directly to the number of channels selected. The following tables show the functions and values for each channel in the four different channel modes (3, 6, 7, and 8).

### 3CH MODE

CH	VALUES	FUNCTION	PRIORITY	REMARKS
1	000 - 255	Red dimming 0-100%		
2	000 - 255	Green dimming 0-100%		
3	000 - 255	Blue dimming 0-100%		

### 6CH MODE

CH	VALUES	FUNCTION	PRIORITY	REMARKS
1	000 - 255	General dimming 0-100%	1	
2	000 - 255	Red dimming 0-100%		
3	000 - 255	Green dimming 0-100%		
4	000 - 255	Blue dimming 0-100%		
5	000 - 014	Dimming	2	
	015 - 255	Strobe (fast-slow)		

6	000 - 031	Not used	3	Must use channels 1-4 to get light. Channel 5 is the speed control.
	032 - 063	Dark-Bright fade		
	064 - 095	Bright-Dark fade		
	096 - 127	Dark-Bright-Dark fade		
	128 - 159	Multicolor gradient		
	160 - 191	Multicolor fade in-out		
	192 - 223	Multicolor jump		
	224 - 255	Sound Activated		

## 7/8CH MODE

CH	VALUES	FUNCTION	PRIORITY	REMARKS
1	000 - 255	General dimming 0-100%	1	
2	000 - 255	Red dimming 0-100%		
3	000 - 255	Green dimming 0-100%		
4	000 - 255	Blue dimming 0-100%		
5	000 - 014	Dimming	3	
	015 - 255	Strobe (fast-slow)		

6	000 - 031	Not used	3	Must use channels 1-4 to get light. Channel 5 is the speed control.
	032 - 063	Dark-Bright fade		
	064 - 095	Bright-Dark fade		
	096 - 127	Dark-Bright-Dark fade		
	128 - 159	Multicolor gradient		Channel 5 is the speed control.
	160 - 191	Multicolor fade in-out		
	192 - 223	Multicolor jump		
	224 - 255	Sound Activated		
7	000 - 009	Not used	2	Channel 1 is master dimmer. Channels 2-4 have no effect.
	010 - 029	R 100%		
	030 - 039	R 85%+Y 15%		
	040 - 049	R 60%+Y 40%		
	050 - 069	Y 100%		
	070 - 079	Y 85%+G 15%		
	080 - 089	Y 60%+G 40%		
	090 - 109	G 100%		
	110 - 119	G 85%+B 15%		
	120 - 129	G 60%+B 40%		
	130 - 149	B 100%		
	150 - 159	B 85%+C 15%		
	160 - 169	B 60%+C 40%		
	170 - 189	C 100%		
	190 - 199	C 50%+P 50%		
	200 - 219	P 100%		

7	220 - 229	P 50%+W 50%	2	Channel 1 is master dimmer. Channels 2-4 have no effect.
	230 - 249	W 95%+Y 5%		
	250 - 255	W 100%		
8	000 - 005	Uses the nodE setting	1	See Channel 8 note below table.
	006 - 055	DIMMING 0		
	056 - 105	DIMMING 1		
	106 - 155	DIMMING 2		
	156 - 205	DIMMING 3		
	206 - 255	DIMMING 4		

**Channel 8 Note:** Similar to the nodE setting, but with variable speed control. DIMMER0 has the fastest range, DIMMER4 the slowest. Depends on the use of channels 1-4. It is recommended to use DIMMING 1 at minimum if using a low res DMX controller.

## CHANGING THE LENS

This light fixture includes a 30° beam angle lens installed, but also includes an 80° beam angle lens for wider dispersion. To change lenses, unscrew the lens ring, remove the installed lens, install the new lens, then screw the lens ring back onto the end of the light.

*Note: Take care to not touch either lens with your bare fingers. Doing so will leave a fingerprint on the lens, which could show on a lighted surface. For best results, wear cloth or rubber gloves when changing the lens.*

## TROUBLESHOOTING

Q1: The light does not turn on and the menu will not display.

A1: Check the power cable to ensure it is properly plugged in. Ensure that the power outlet is live by plugging in a different device.

Q2: The light will not turn on, but the menu does display.

A2: Using the menu, ensure that all the color dimmers are not set to 000.

Q3: The light does not respond to DMX commands.

A3: Ensure that the light is set to DMX mode with a valid DMX address.

Check for address conflicts with other devices. Try swapping out the DMX cable with a known good one. Ensure that there is a DMX terminator connected to the **DMX Out** connector of the final fixture in the daisy-chain. Verify that the DMX controller is operating properly by using it with another DMX device.

## TECHNICAL SUPPORT

Monoprice is pleased to provide free, live, online technical support to assist you with any questions you may have about installation, setup, troubleshooting, or product recommendations. If you ever need assistance with your new product, please come online to talk to one of our friendly and knowledgeable Tech Support Associates. Technical support is available through the online chat button on our website [www.monoprice.com](http://www.monoprice.com) during regular business hours, 7 days a week. You can also get assistance through email by sending a message to [tech@monoprice.com](mailto:tech@monoprice.com)

## SPECIFICATIONS

Model	612768
Light Source	1x 80-watt RGB 3-in-1 COB LED
LED Lifespan	50,000 ~ 100,000
Input Power	100 ~ 260 VAC, 50/60 Hz
Power Consumption	85 watts
Beam Angle	30° (default) or 80°
Refresh Rate	1.5 kHz, flicker-free for TV and camera shooting
Signal Input	3-pin XLR male
Signal Output	3-pin XLR female
Control Modes	Standalone, Master/Slave, Auto, Sound Activated
Functions	Dimmer, Strobe, Jump, Gradual Change
Ingress Protection Rating	IP20
Anti-Electricity Intension	> 1.5kV
Insulation Resistance	> 2MΩ
Cooling	Natural convection
Dimensions	5.5" x 8.1" x 11.1" (139 x 205 x 281 mm)
Weight	3.3 lbs. (1.5kg)



# REGULATORY COMPLIANCE

## Notice for FCC



This device complies with Part 15 of the FCC rules. Operation is subject to the following two conditions: (1) this device may not cause harmful interference, and (2) this device must accept any interference received, including interference that may cause undesired operation.

Modifying the equipment without Monoprice's authorization may result in the equipment no longer complying with FCC requirements for Class B digital devices. In that event, your right to use the equipment may be limited by FCC regulations, and you may be required to correct any interference to radio or television communications at your own expense.

This equipment has been tested and found to comply with the limits for a Class B digital device, pursuant to Part 15 of the FCC Rules. These limits are designed to provide reasonable protection against harmful interference in a residential installation. This equipment generates, uses and can radiate radio frequency energy and, if not installed and used in accordance with the instructions, may cause harmful interference to radio communications. However, there is no guarantee that interference will not occur in a particular installation. If this equipment does cause harmful interference to radio or television reception, which can be determined by turning the equipment off and on, the user is encouraged to try to correct the interference by one or more of the following measures:

- Reorient or relocate the receiving antenna.
- Increase the separation between the equipment and receiver.
- Connect the equipment into an outlet on a circuit different from that to which the receiver is connected.
- Consult the dealer or an experienced radio/TV technician for help.

## Notice for Industry Canada

This Class B digital apparatus complies with Canadian ICES-003.

Cet appareil numérique de la classe B est conforme à la norme NMB-003 du Canada.