

4 Locking Adapter Brackets

- First, pull the outside safety straps on the adapter brackets, and then slowly allow display to return to the wall. Finally loosen the safety straps and lock the adapter brackets.

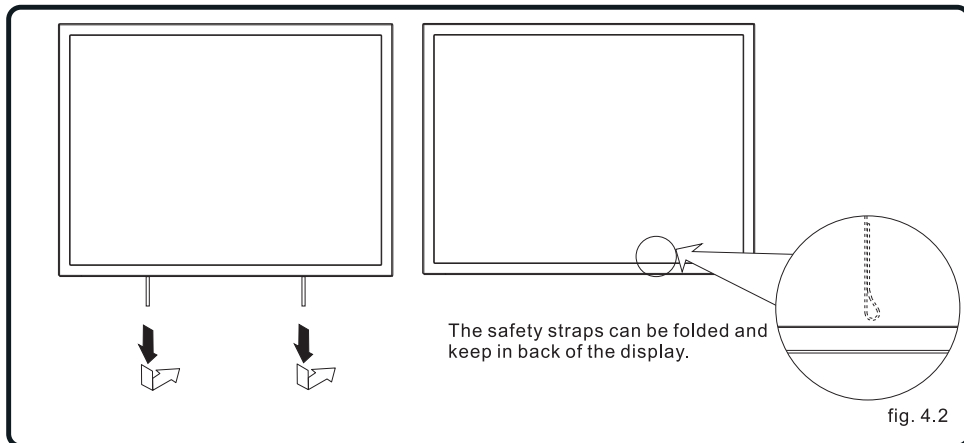
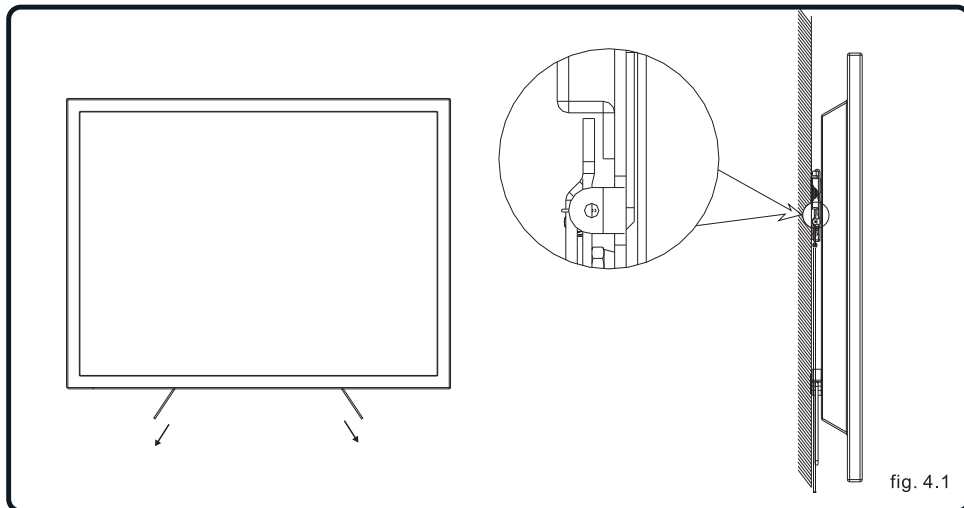

Important: Make sure the TV is correctly hooked and the safety locking bars are locked safely.

Maintenance

- Once you have mounted the bracket and the flat screen, check that they are sufficiently secure and safe to use,
- You should regularly check that the screws and hardware are secure to your wall every two months for safety.
- If you have any doubts regarding the installation, please consult our retailer or service department for further details.

MONOPRICE®

PID 7468

Ultra Low Profile **Wall Mount Bracket**

for LED TV (Max 110Lbs, 32 ~55inch)

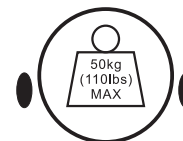
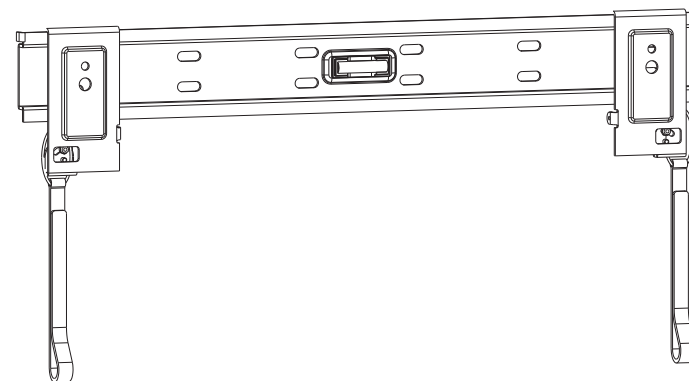

CAUTION: This mount is intended for use only with the maximum weights indicated. Use with products heavier than the maximum weights indicated may result in instability causing possible injury.



NOTE: Read entire instruction sheet before you start installation and assembly.

⚠ WARNING

- Do not begin the installation of the product, until you have read and understood the instructions and warnings provided in the installation manual. If you have any questions regarding the warnings and instructions, please contact your local supplier.
- Please refer to the manufacturers installation guide for proper wall recommendation distance to avoid the risk of property damage.
- This product should only be installed by someone of good mechanical aptitude, with experience and basic building, and fully understands.
- Make sure that the supporting surface will safely support the combined load of the equipment and all attached hardware and components.
- Never exceed the Maximum Load Capacity.
- If mounting to wood wall studs, make sure that mounting screws are anchored into the center of the studs. Use of an “edge to edge” stud finder is highly recommended.
- Always use an assistant or mechanical lifting equipment to safely lift and position equipment.
- Tighten screws firmly, but do not over tighten. Over tightening can damage the items, greatly reducing their holding power.
- This product is intended for indoor use only. The use of this product other than indoors could lead to product failure and personal injury,

Component Checklist

IMPORTANT: Please ensure all parts listed are included prior to your installation. If any parts are missing or faulty, please contact the special franchiser for a replacement.

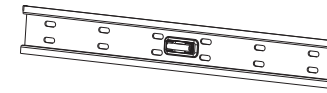

Wall plate (x1)
A

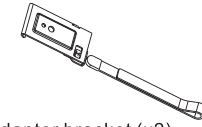

Adapter bracket (x2)
B



Supporting spacer (x1)
C

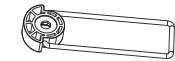

Supporting spacer (x1)
D

Package M



M5x14 (x4)
M-A

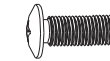

M6x14 (x4)
M-B

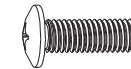

M8x20 (x4)
M-C



M6x30 (x4)
M-D



M8x30 (x4)
M-E



D5 washer(x4)
M-F



D8 washer(x4)
M-G



small spacer (x8)
M-H



big spacer (x4)
M-I

Package W

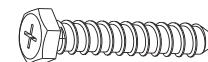

ST6.3x55 (x6)
W-A

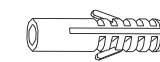

concrete anchor (x6)
W-B



D6 washer (x6)
W-C

Tools required

- Phillips Head Screw driver(200mm length exclude the handle)
- M6 Socket and Wrench
- Electric drill and 10mm masonry bit for concrete wall installation
- Marking Pen
- Hammer

1a WOOD STUD WALL MOUNTING:

⚠ WARNING

- Make sure that the supporting surface will safely support the combined load of the equipment and all attached hardware and components.
- Tighten wood screws firmly, but do not overtighten. Overtightening can damage the screws, greatly reducing their holding power.
- Make sure that mounting screws are anchored into the center of the studs. Use of an “edge to edge” stud finder is highly recommended.
- Hardware provided is for attachment of mount through standard thickness drywall or plaster into studs. Installers are responsible to provide hardware for other types of mounting situations.

- Wall plate can be mounted to two studs. Use a stud finder to locate the edges of the studs. Use of an edge-to-edge stud finder is highly recommended. Based on their edges, draw a vertical line down each stud's center.
- Place wall plate on wall as a template. And mark the center of the four mounting holes. Make sure that the mounting holes are on the stud centerline.
- Drill four 3/16" (4.5mm) dia. Holes 2.2" (55mm) deep, secure it using four lag bolts (W-A) and four M6 washers (W-C) as shown in fig. 1.1.

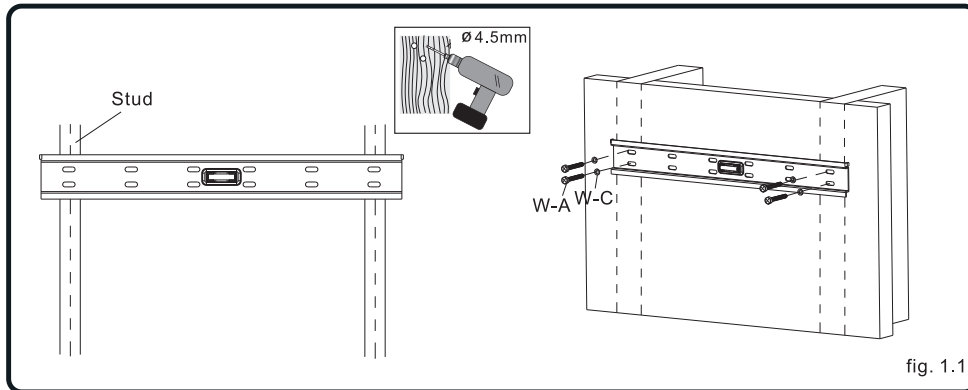

1b SOLID BRICK AND CONCRETE BLOCK MOUNTING:

⚠ WARNING

- When installing wall mounts on cinder block, verify that you have a minimum of 1-3/8" of actual concrete thickness in the hole to be used for the concrete anchors. Do not drill into mortar joints! Be sure to mount in a solid part of the block, generally 1" minimum from the side of the block. It is suggested electric drill on slow setting is used to drill the hole instead of a hammer drill to avoid breaking out the back of the hole when entering a void or cavity.
- Installer must verify that the supporting surface will safely support the combined load of the equipment and all attached hardware and components.

- Use the Wall Plate as a template to mark 6 holes locations on the wall. As shown in fig.1.2.
- Pre-drill these holes with a 10mm masonry bit to at least 60mm in depth. Insert a Concrete Anchor (W-B) into each of these holes. Attach the Wall Plate to the wall using 6 Lag Bolts (W-A) and 6 M6 Washers (W-C), as in fig.1.3.

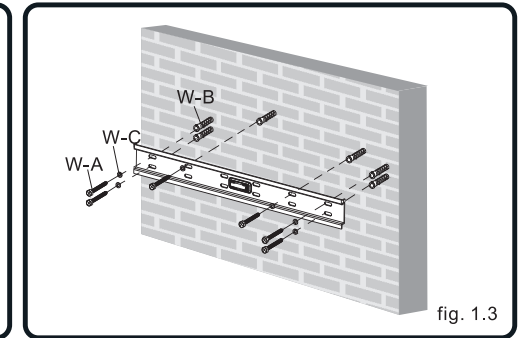
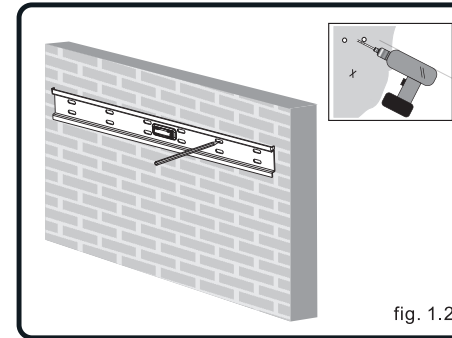

2 Installing Adapter Brackets

- To prevent scratching the screen, set a cloth on a flat, level surface that will support the weight of the screen.
- Place screen face side down. Place adapter bracket and supporting spacer on the back of screen, align to holes, as shown in fig.2.1.
- Attach the adapter brackets and supporting spacer to the back of the screen using the appropriate combination of screws, washers, and spacers, as shown in fig.2.2, fig.2.3 and fig.2.4.

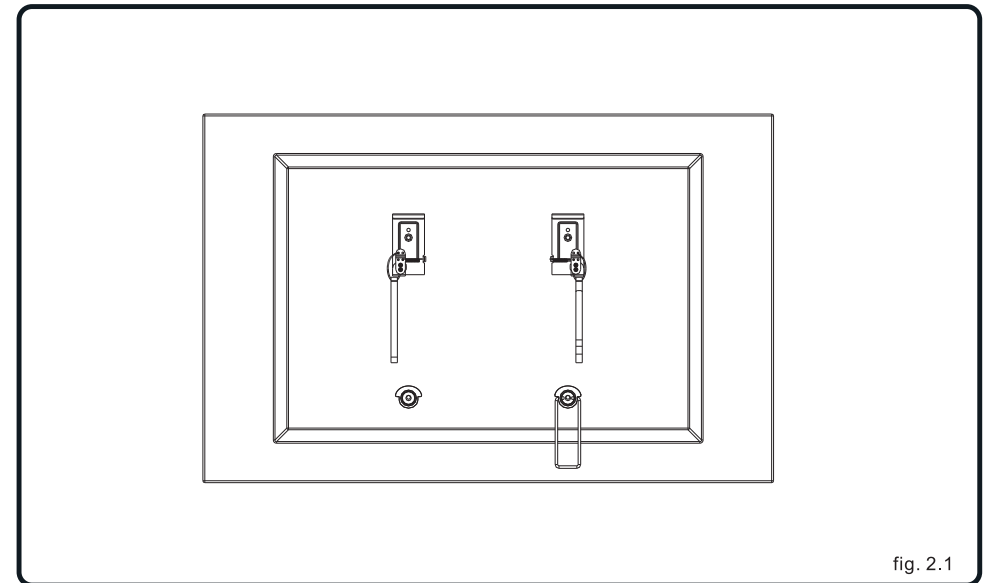

NOTE: For flat back screens proceed to step 2-1. For bump-out or recessed back screen skip to step 2-2.

2
1

For Flat Back Screen

- Begin with the shortest length screw, hand thread through washer and adapter bracket into screen as shown below.
- Screw must make at least three full turns into mounting hole and fit snug into place. Do not over tighten.
- If screw cannot make three full turns into screen, select a longer length screw. Repeat for remaining mounting holes, and tighten screws.

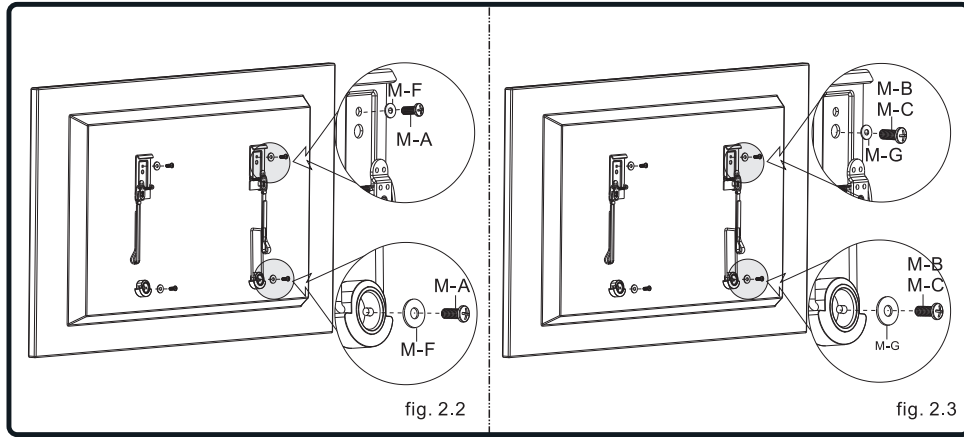

2
2

For Bump-out or Recessed Back Screen

- Begin with longer length screw, hand thread through washer, the supporting spacers and spacers into screen as shown below. Screw must make at least three full turns into mounting hole and fit snug into place. Do not over tighten. If screw cannot make three full turns into screen, select a longer length screw from the baffled fastener pack. Repeat for remaining mounting holes and tighten screws.

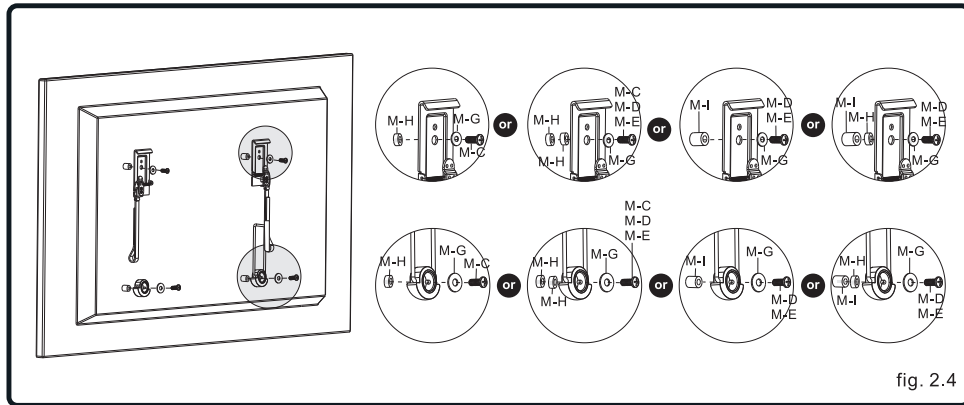

Hang the brackets mounted TV onto the wall plate

3
1

Warning: A minimum of two qualified people are required for this operation.

- After the wall mount has been safely secured to the wall, with 2 people carefully lift your TV and hook the top hooks over the top of the wall plate rail, see Fig. 3.1.

3
2

Cable Management

- Slowly pull bottom of display away from wall until kickstand of the supporting spacer(D) fully reaches its down position.
- Attach or adjust cables as necessary on back of display.
- To disengage kickstand, slightly pull display away from wall. Slowly allow display to return to the wall.

