



INSTALLATION GUIDE

Flat Panel Arm Mount

MHA-200

Support 23" to 40" Screens

Max Load Capacity: 80 lbs (36 kg)

VESA 100x100/200x100/200x200 compatible

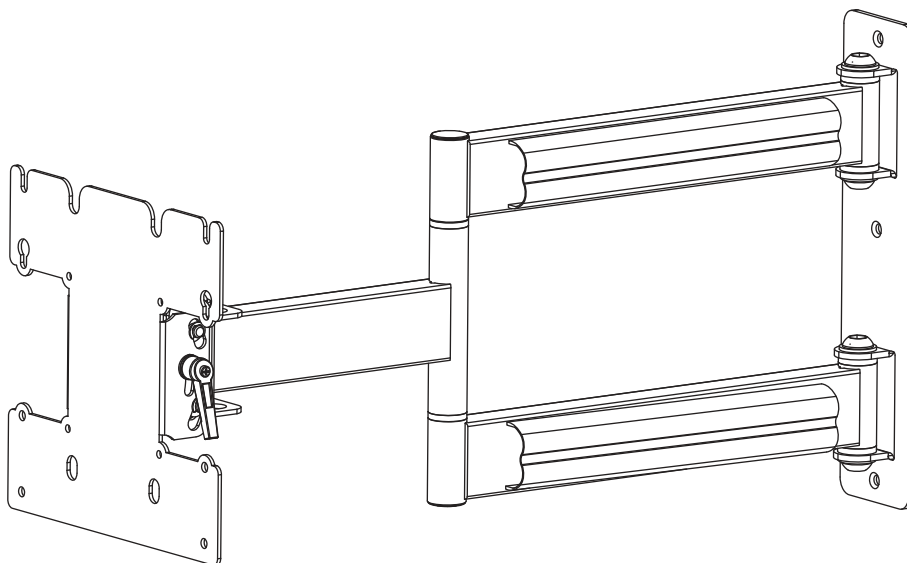

WARNING

- Be sure to read this entire manual thoroughly and you fully understand all the instructions and warning before attempting to begin your installation.
- This product should only be installed by someone who has a basic knowledge of building construction, installations and fully understands these instructions.
- Make sure that the supporting surface will safely support the combined load of the mount, the display and all attached hardware and components.
- This wall bracket will only supporting flat panel displays(LCD,Plasma).The maximum load capacity is 80 pounds.
- If mounting to a wall of wood stud construction, be sure that mounting bolt are anchored to the center of the studs.
- Always have someone assist you to lift and position your equipment.
- Tighten screws and bolts firmly, but do not over tighten. Over tightening can damage the items and greatly reduce their ability to hold. Please refer to suggested torque values where applicable in these instructions.

Tools Needed for Assembly

- stud finder ("edge to edge" stud finder is recommended)
- phillips screwdriver
- pencil
- drill
- 3/16" drill bit for wood studs, 5/16" drill bit for concrete
- level
- tape measure

Table of Contents

Parts List	3
Installation to Single Wood Stud Wall	4
Installation to Solid Concrete and Cinder Block	5
Attaching the mount to Screens with VESA® Mounting Patterns	6,7
Cable Management	8

Before you begin, make sure all parts shown are included with your product.
Parts may appear slightly different than illustrated.

Parts List

	Description			
A	philips pan head screw	4	M4x0.7x10	
B	philips pan head screw	4	M4x0.7x20	
C	philips pan head screw	4	M6x1x12	
D	philips pan head screw	4	M6x1x20	
E	philips pan head screw	4	M6x1x30	
F	spacer	4		
G	cross slotted head screw	3	M6x60	
H	concrete anchor	3	M6x40	
AA	mount	1		

A

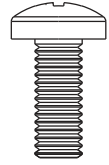

B

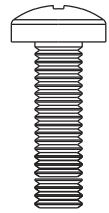

C

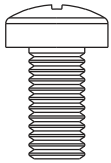

D

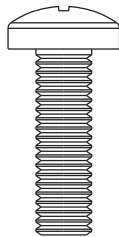

E

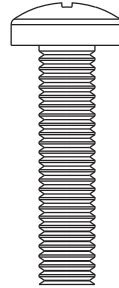

F

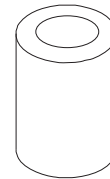

G

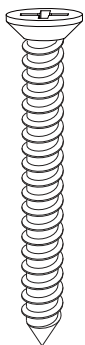

H

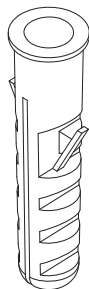

AA

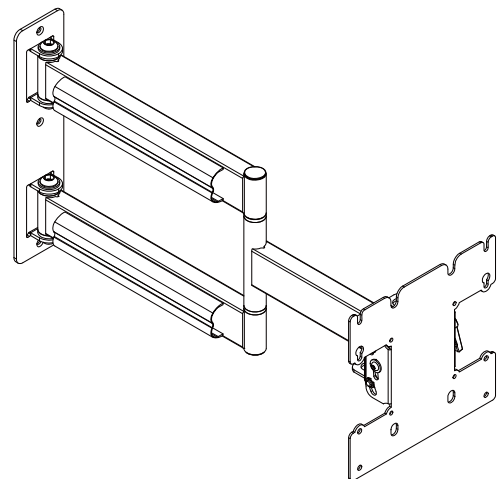

Installation to Single Wood Stud Wall

⚠ WARNING

- Installer must verify that the supporting surface will safely support the combined load of the equipment and all attached hardware and components.
- Tighten wood screws so that wall plate is firmly attached, but do not overtighten. Overtightening can damage the screws, greatly reducing their holding power.
- Make sure that mounting screws are anchored into the center of the stud. The use of an "edge to edge" stud finder is highly recommended.
- Hardware provided is for attachment of mount through standard thickness drywall or plaster into wood studs. Installers are responsible for providing hardware for other types of mounting situations.

- A** Using a stud finder, locate and mark the edges of the wood stud. Use of an edge to edge stud finder is highly recommended. Use a level to draw a vertical line down the center of the stud. Use the wall plate of the mount(AA) as a template to mark the center of holes along the vertical line. The top mounting holes should be 5" above the desired screen center as shown in figure A.1. Drill three 3/16" (5 mm) dia. pilot holes 2" (76 mm) deep. Attach the mount(AA) to wall using three M6 X 60 cross slotted head screw (G) as shown in fig. A.2. Level the plate, then tighten all fasteners.

CS = center of screen **fig. A.1**

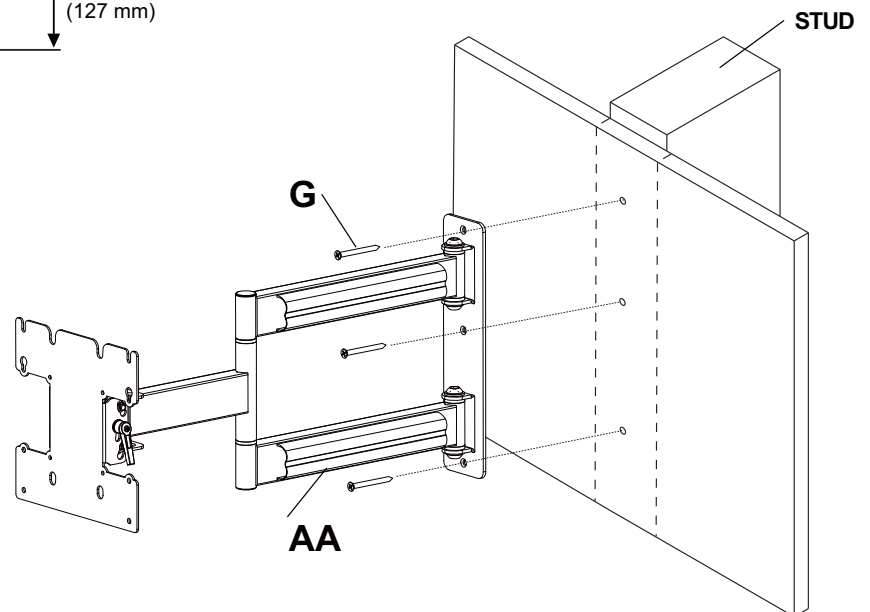
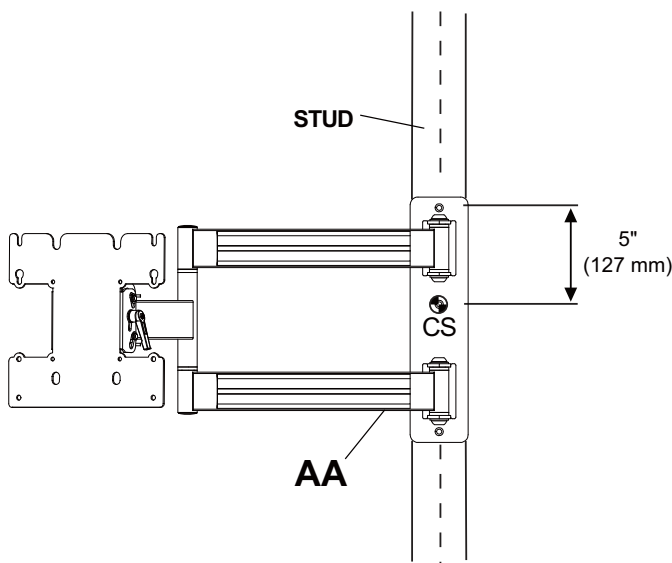

fig. A.2

Installation to Solid Concrete or Cinder Block

⚠ WARNING

- When installing the wall mount to cinder block, verify that you have a minimum of 1-3/8" of actual solid concrete thickness in the hole to be used for the concrete anchors. Do not drill into mortar joints! Be sure to mount in a solid part of the block, generally 1" minimum from the side of the block. Cinder block must meet ASTM C-90 specifications. It is recommended that a standard electric drill set on a slow setting is used to drill the hole instead of a hammer drill to avoid breaking out the back of the hole when entering a void or cavity.
- Concrete must have a 2000 psi density minimum. Lighter density concrete may not hold the concrete anchor.
- Make sure that the supporting surface will safely support the combined load of the equipment and all attached hardware and components.

- B** Use wall plate (AA) as template to mark mounting holes. The top mounting hole should be 5" above the desired screen center as shown in figure A.1 on page 4. Drill three 5/16" (8 mm) dia. holes 2" (50 mm) deep as shown in fig. B.1. Insert concrete anchor (H) in holes flush with the wall as shown (right). Place wall plate over anchors and secure with M6x 60 screws (G). Level, then tighten all fasteners.

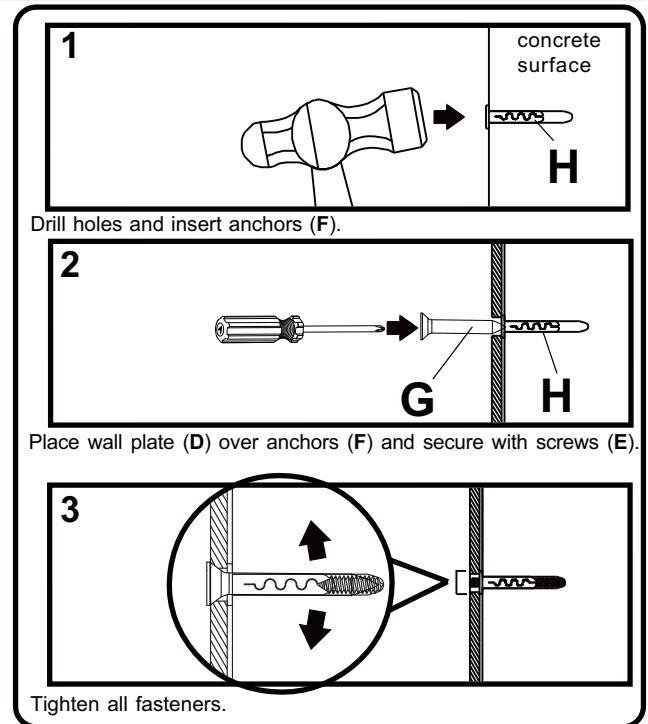

⚠ WARNING

- Tighten screws so that wall plate is firmly attached, but do not overtighten. Overtightening can damage screws, greatly reducing their holding power.

⚠ WARNING

- Always attach concrete anchors directly to load-bearing concrete.
- Never attach concrete anchors to concrete covered with plaster, drywall, or other finishing material. If mounting to concrete surfaces covered with a finishing surface is unavoidable, the finishing surface must be counterbored as shown below. Be sure concrete anchors do not pull away from concrete when tightening screws. If plaster/drywall is thicker than 5/8", custom fasteners must be supplied by the installer.

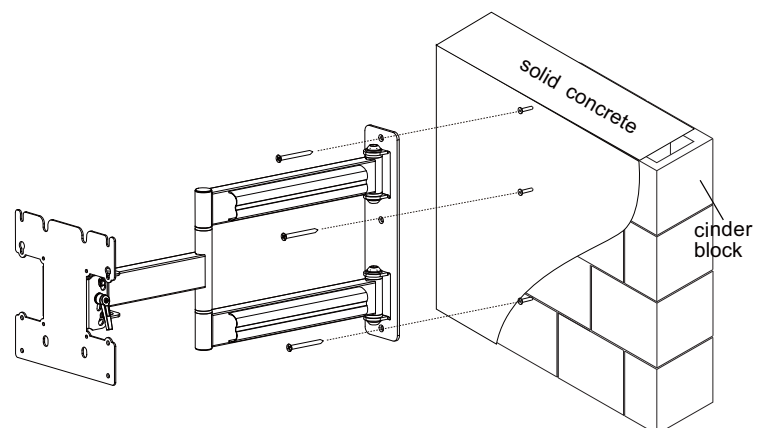
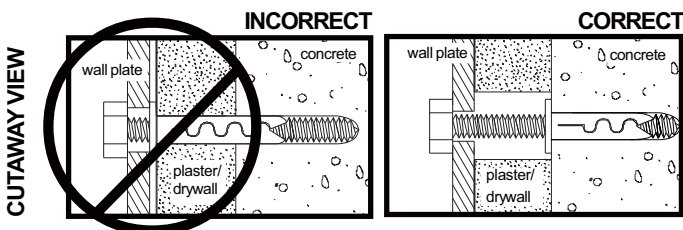
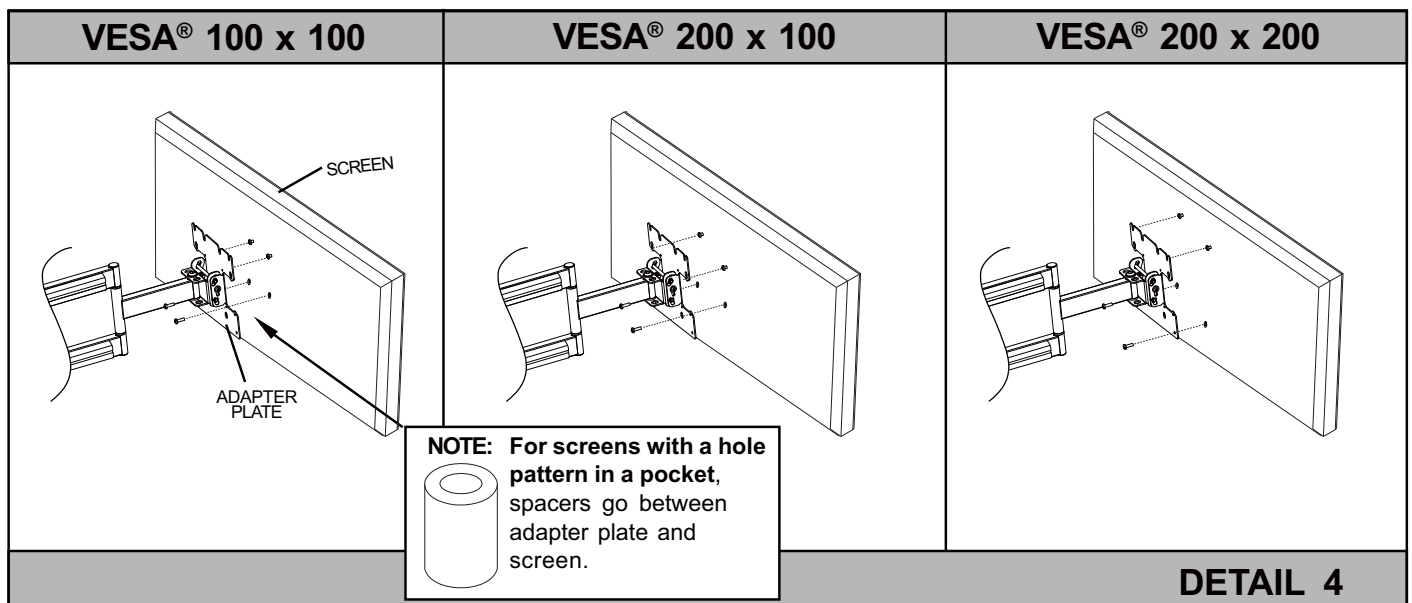
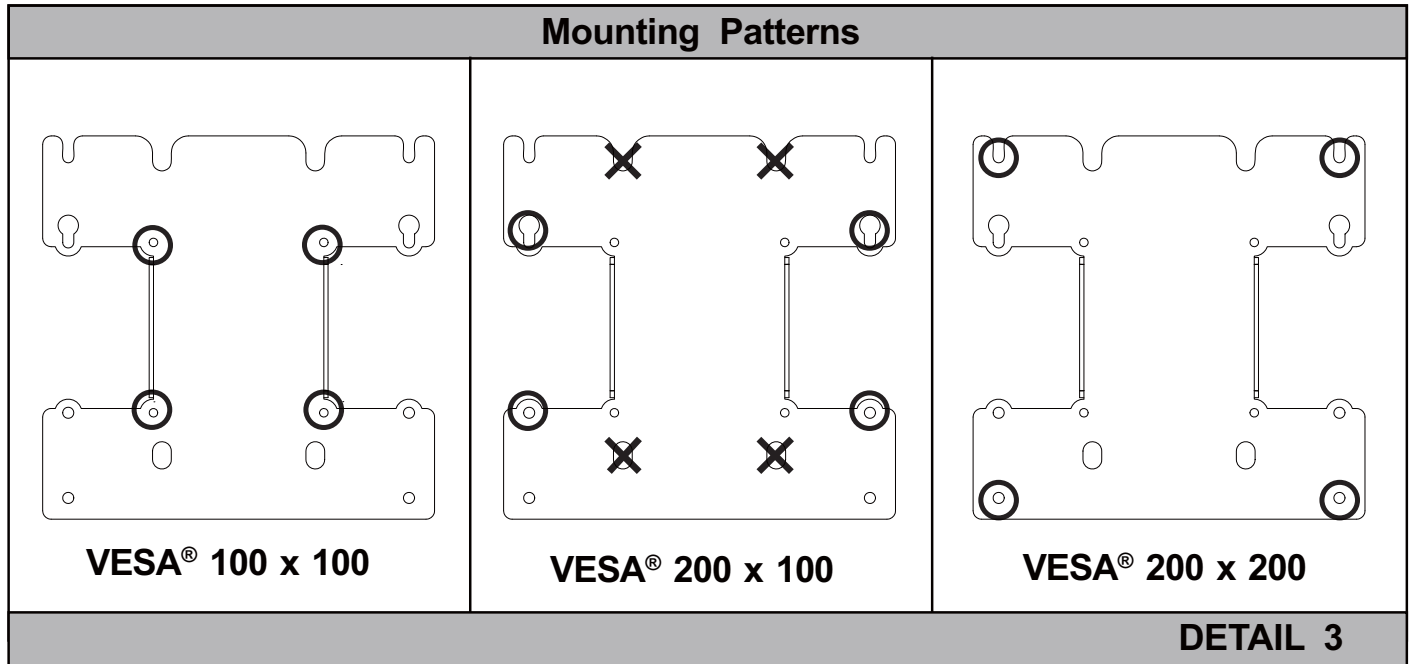

fig. B.1

Attaching display mounting plate (AA) to a Screen with a VESA® Mounting Pattern

C Choose hole pattern as shown in detail 3 for VESA mounting pattern. Begin with the shortest length screw, hand thread through adapter plate into screen as shown in detail 4. Screw must make at least three full turns into the mounting hole and fit snug into place. Do not over tighten. If screw cannot make three full turns into the screen, select a longer length screw from the fastener pack. Repeat for remaining mounting holes. Securely tighten screws.

NOTE: Spacers do not have to be used, depending upon the type of screen.



C.1**For Flat Back Screen**

fig C.1.1

OR**For Beveled Back Screen**

fig C.1.2

Select the small, medium, large or extra large screws from the baffled fastener pack then attach screen brackets(AA) to screen following figure C.1.1 or C.1.2 on page 7.

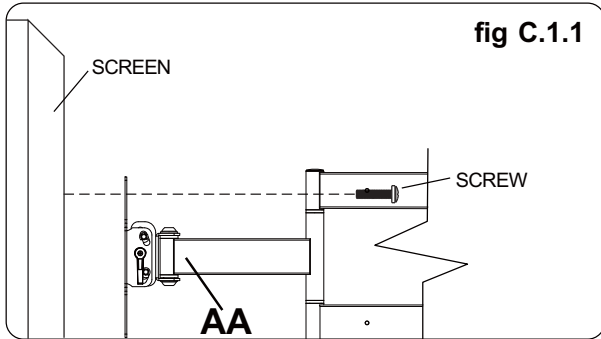
C.2

Insert two for 200x200 & 200x100 VESA patterns appropriate sized bolts(C) into the top two mounting holes on the back of your display as shown in **fig.C.2.1** Leave approx. 1/4" of exposed thread.

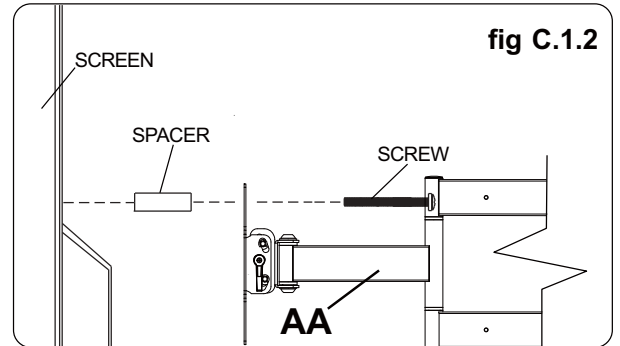
Lift the display and hook it on to the display mounting plate by lowering the exposed portion of the top screws down the notches on the top edge of the plate for a 200x200 pattern or into the key hole.

Once in position, attach the bottom two for a 200x200 pattern bolts(C) to secure the display to the mounting plate as shown in **fig.C.2.2**

⚠ WARNING

- Do not lift more weight than you can handle. Use additional man power or mechanical lifting equipment to safely handle placement of the screen.

CAUTION

- Do not tighten screws with excessive force. Overtightening can cause damage to mount.

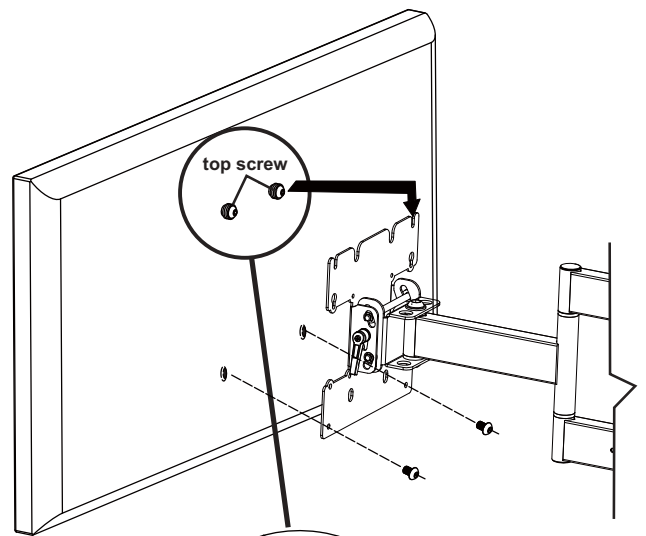

fig.C.2.2

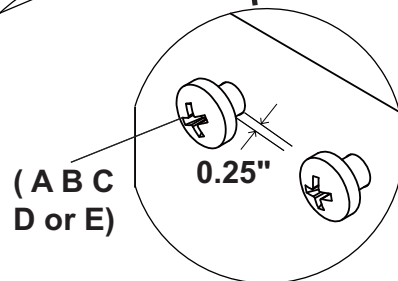

fig.C.2.1

E Adjust tension knob on side of mount as shown in **fig. E.1** to desired tension to balance your screen size and weight.

The tension knob, without changing the bracket tension, can be pulled out, away from the bracket and turned independently of the knob post for readjustment as shown in **fig.E.2**.

Push or pull from top or bottom of screen to adjust tilt as shown. The tilt can be adjusted to a maximum of -5° forward or $+15^{\circ}$ backward

⚠ CAUTION

- Be careful not to pinch fingers when opening and closing mount from the wall.

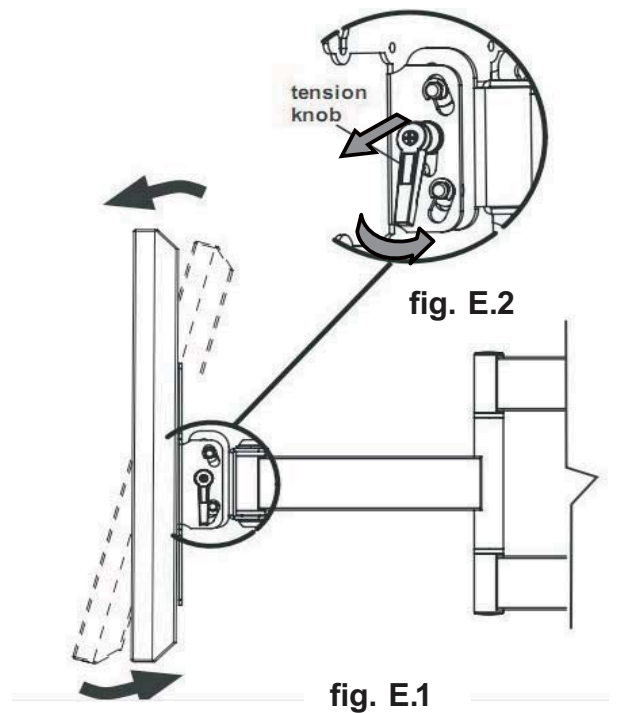

F Cable Management

Note: Make sure cords have enough slack to allow full movement of the arm. Route cords inside arm slots of wall arm assembly (**AA**) as shown in **fig.F.1**. For demonstration purposes, the wall has been omitted from the image.

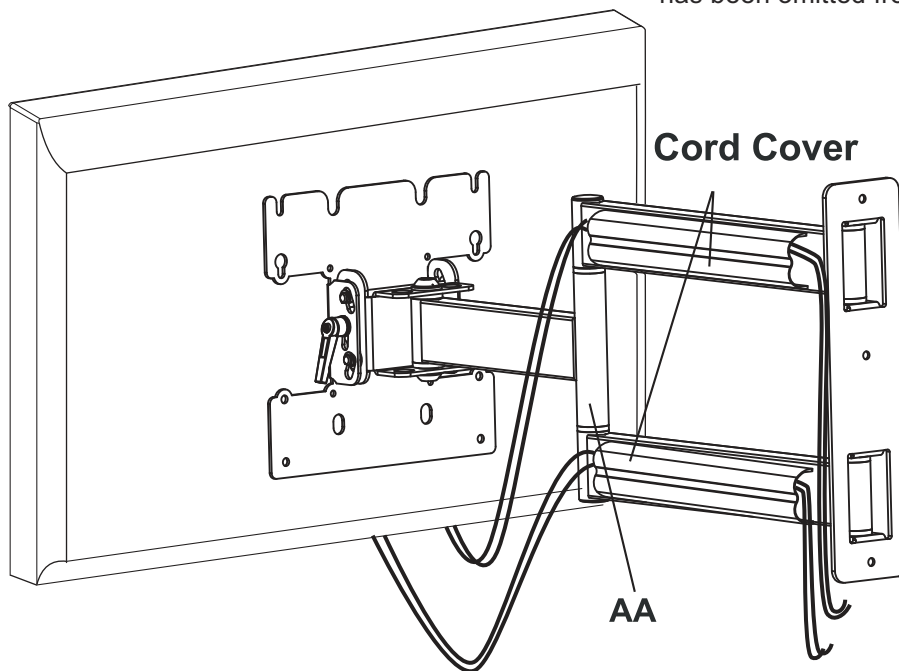

fig.F.1

⚠ WARNING

- Do not remove or loosen screw while the mount is in use. Doing so may cause the screen to fall.